

## Model WP-9 / WP-9V / WP-9P / Air Cooled Tig Torches / 125 AMPS

Versatile & lightweight for thin gauge material



WP-9V



WP-9P

Note: If other than standard power cable is desired for air cooled torch, change last character to receive desired power cable.

-1: One piece vinyl jacketed power cable

-2: Two piece power cable

-R: One piece rubber jacketed power cable

Part No.	Description	Max Amps	Head Angle	Gas Valve	Handle Style	Access Kit	Hook-Up Kit	Cable
WP-9 WP-9-12-2 WP-9-25-2	Torch Body Torch Package Torch Package	125	70°	No	Ribbed 3/4 Dia.	AK-1	HK-3	2-Piece Power Cable
WP-9V WP-9V-12-2 WP-9V-25-2	Torch Body, Valve Torch Package Torch Package	125	70°	Knob & Stem	Ribbed 3/4 Dia.	AK-1	HK-2	2-Piece Power Cable
WP-9P WP-9P-12-1 WP-9P-25-1	Torch Body Torch Package Torch Package	125	180°	No	Textured 3/4 Dia.	AK-1A	HK-3	1-Piece Vinyl Power Cable
WP-9P-12V-1 WP-9P-25V-1	Torch Package Torch Package	125	180°	Slide	Smooth 3/4 Dia.	AK-1A	HK-2	1-Piece Vinyl Power Cable

Torch bodies only include cup gasket

Torch Packages include: Torch body, handle, medium back cap (WP-9P torch does not use back caps), and power cable. Power cable adapter must be ordered separately.

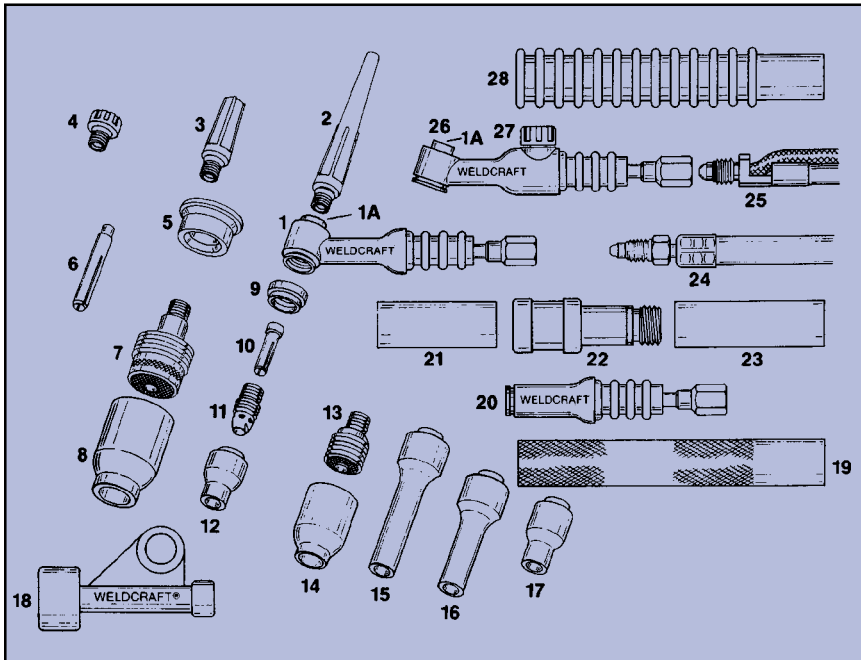

Chart A: Collets, Collet Bodies, Gas Lens

Electrode Diameter	.020	.040	1/16	3/32
Collet	13N20	13N21	13N22	13N23
Collet Body	13N25	13N26	13N27	13N28
Gas Lens	45V41	45V42	45V43	45V44
Lg. Dia. Gas Lens Collet	13N20L	13N21L	13N22L	13N23L
Lg. Dia. Gas Lens	45V0204S		45V116S	45V64S

Chart B: Gas Nozzles, HPN - High Performance Nozzles Available

SIZE	3	4	5	6	7	8	10	12	SHORT
Alumina		13N08	13N09	13N10 •	13N11 •	13N12	13N13		
Alumina Gas Lens		53N58 •	53N59 •	53N60 •	53N61 •	53N61S •			
Large Diameter Gas Lens				57N75		57N74	53N88 •	53N87 •	53N89*
Lava		13N14	13N15	13N16	13N17	13N18	13N19		
Long Lava**	796F70	796F71	796F72	796F73					
Ex Long Lava	796F74	796F75	796F76	796F77					

\* Not recommended for use with high frequency current

\*\* Also available in alumina. Ex: A796F70

• HPN Nozzle available.

Item No.	Part No.	Description
1	WP-9	Torch body, includes cup gasket (70°)
1A	09-4	Insert
2	41V24	Long back cap, includes 98W77 O-ring
3	41V35	Medium back cap, includes 98W77 O-ring
4	41V33	Short back cap, includes 98W77 O-ring
5	54N63-20	Lg. diameter gas lens insulator
6	-	Lg. diameter gas lens collet (See chart A)
7	-	Lg. diameter gas lens (See chart A)
8	-	Lg. diameter gas lens nozzle (See chart B)
9	598882	Cup gasket
10	-	Collet (See chart A)
11	-	Collet body (See chart A)
12	-	Alumina nozzle (See chart B)
13	-	Gas lens (See chart A)
14	-	Alumina gas lens nozzle (See chart B)
15	-	Extra long lava nozzle (See chart B)
16	-	Long lava nozzle (See chart B)
17	-	Lava nozzle (See chart B)
18	105Z57	Power cable adapter
19	H-100	Handle (smooth, standard on WP-9P)
20	WP-9P	Pencil torch body, includes cup gasket (180°)
21	V-92-1	Front handle
22	V-92-2	Valve body
23	V-92-3	Rear handle
	V-92	Valve assy, includes items 21, 22, 23
24	-	Power cable - 1 piece
		57Y01 12-1/2 ft. (3.8 m) vinyl
		57Y03 25 ft. (7.6 m) vinyl
		57Y01R 12-1/2 ft. (3.8 m) rubber
		57Y03R 25 ft. (7.6 m) rubber
25	-	Power cable - 2 piece <b>Gas hose only</b>
		57Y01-2 12-1/2 ft. (3.8 m) 45V09R
		57Y03-2 25 ft. (7.6 m) 45V10R
26	WP-9V	Valve torch body, includes cup gasket and valve stem (70°)
27	VS-2	Valve stem, includes 98W77 O-ring
28	H-100R	Handle (ribbed, standard on WP-9V, 9)
	ZCRK17	<b>Cable Repair Kits</b>
	ZCRK17-2	One-piece power cable repair kit
		Two-piece power cable repair kit

**Cable Covers:** WC-3-10, WC-3-22  
**Extension Kit:** EK-2-25-R  
**Quick Connect:** ADD O in front of torch package or cable #  
**Weight:** 3 oz. (less power cable)  
**Torch Length:** WP-9: 7" WP-9P: 6-1/2"

**Model WP-12 / Water Cooled Tig Torch / 500 AMPS**



**Totally sealed water chamber with heavy duty components**

Truly heavy duty performer with a unique water cooling design. Heavy duty collets, collet bodies and gas lens.

Part No.	Description	Max Amps	Head Angle	Gas Valve	Handle Style	Access Kit	Hook-Up Kit	Cable
WP-12	Torch Body	500	70°	No	Smooth	AK-7	HK-1	
WP-12-12	Torch Package				1-3/8 Dia.			
WP-12-25	Torch Package							1-Piece Rubber Power Cable

Torch bodies only include nozzle gasket

Torch Packages include: Torch body, handle, long back cap, hose & power cable assembly in rubber sheath. Power cable adapter must be ordered separately.

Notes: 1.5 - 2 quarts per minute at 50 PSI pressure

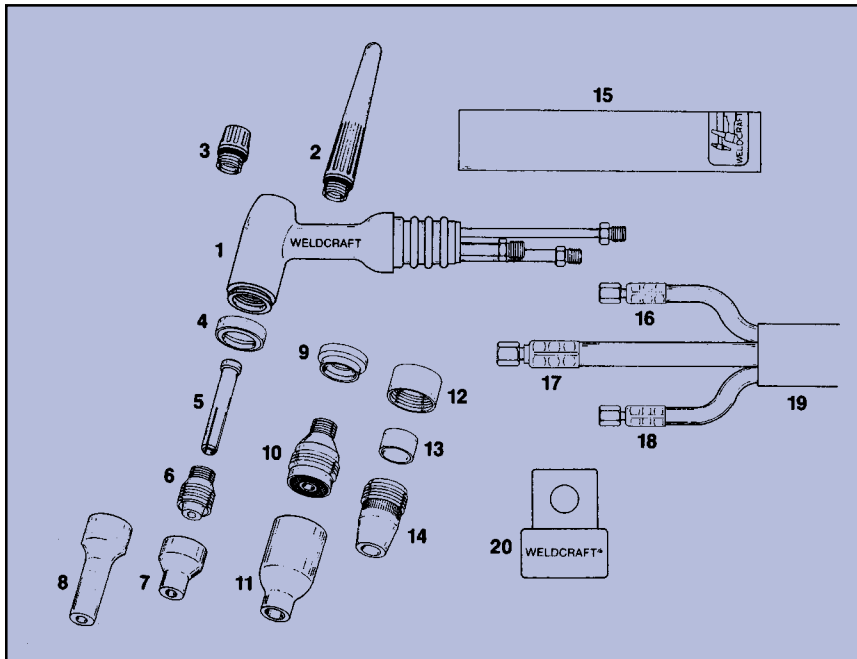

Item No.	Part No.	Description
1	WP-12	Torch body, includes nozzle gasket (70°)
2	56Y44	Long back cap, includes 85W50 O-ring
3	56Y45	Short back cap, includes 85W50 O-ring
4	12NG	Nozzle gasket
5	-	Collet (See chart A)
6	11WP65	Collet body (all sizes)
7	-	Alumina nozzle (See chart B)
8	-	Long alumina nozzle (See chart B)
9	12GLG	Gas lens gasket
10	-	Gas lens (See chart A)
11	-	Gas lens alumina nozzle (See chart B)
12	12MNG	Metal nozzle gasket
13	85Z99	Insulator sleeve
14	-	Metal nozzle (See chart B)
15	85WP13	Handle
16	-	Gas hose 40V82R 12-1/2 ft. (3.8 m) 40V82RL 25 ft. (7.6 m)
17	-	Power cable 40V84R 12-1/2 ft. (3.8 m) 40V84RL 25 ft. (7.6 m)
18	-	Water hose 40V83R 12-1/2 ft. (3.8 m) 40V83RL 25 ft. (7.6 m)
19	-	Hose and cable assy. in rubber sheath 40WP84 12-1/2 ft. (3.8 m) 40WP84L 25 ft. (7.6 m)
20	45V11	Power cable adapter

**Chart A: Collets, Collet Bodies, Gas Lens**

Electrode Diameter	1/16	3/32	1/8	5/32	3/16	1/4
Collet	85Z14	85Z15	85Z16	85Z17	85Z18	85Z19
Gas Lens	11GL16	11GL32	11GL18	11GL53	11GL36	
Collet Body	11WP65					

Notes: Water cooled torches require cooling water flow of 1.5 - 2 quarts per minute at 50 PSI pressure

**Chart B: Gas Nozzles, HPN - High Performance Nozzles Available**

SIZE	4	5	6	7	8	10	12	SHORT
Alumina	14N57	14N58	14N59	14N60 •	14N61 •	14N61-10 •	14N61-12 •	
Long Alumina	14N68	14N69	14N70	14N71	14N72			
Gas Lens			57N75		57N74	53N88 •	53N87 •	53N89**
Metal*			86Z01		86Z02	86Z03	86Z06	

\* Requires 85Z99 insulator sleeve

\*\* Not recommended for use with high frequency current

• HPN Nozzle available.

**Cable Covers:** WC-4-10, WC-4-22  
**Extension Kit:** EK40WP84L  
**Quick Connect:** ADD Q in front of torch package or cable #  
**Weight:** 15 oz. (less hose and cable assembly)  
**Torch Length:** 11-1/2"

## Model WP-17 & WP-17V / Air Cooled Tig Torches / 150 AMPS



Part No. WP-17

### High capacity for thin to medium gauge materials

Compact and durable for field welding applications. Ribbed handle for comfort and cool operation. Fingertip gas control valve on WP-17V model and heavy duty 2 pc. power cable is supplied as standard equipment. Parts interchange with WP-18, WP-26, and WP-26V models.

Note: If other than standard power cable is desired for air cooled torch, change last character to receive desired power cable.  
-1: One piece vinyl jacketed power cable  
-2: Two piece power cable  
-R: One piece rubber jacketed power cable

Part No.	Description	Max Amps	Head Angle	Gas Valve	Handle Style	Access Kit	Hook-Up Kit	Cable
WP-17 WP-17-12-2 WP-17-25-2	Torch Body Torch Package Torch Package	150	70°	No	Ribbed 7/8 Dia.	AK-2	HK-3	2-Piece Power Cable
WP-17V WP-17V-12-2 WP-17V-25-2	Torch Body Torch Package Torch Package	150	70°	Knob & Stem	Ribbed 7/8 Dia.	AK-2	HK-2	2-Piece Power Cable

Torch body includes cup gasket

Torch Packages include: Torch body, handle, long back cap, power cable. Power cable adapter is not needed with two piece power cable.

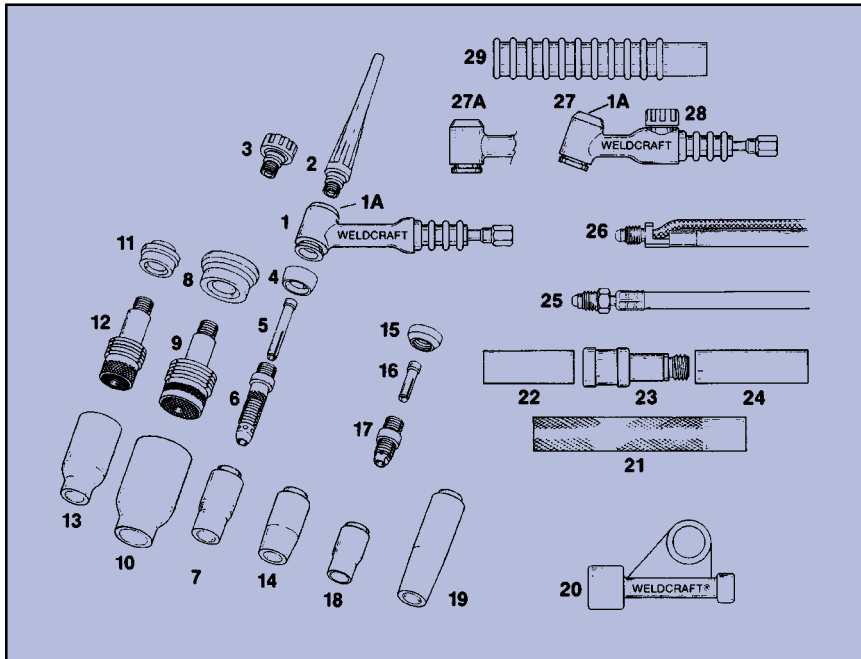

Chart A: Collets, Collet Bodies, Gas Lens

Electrode Diameter	.020	.040	1/16	3/32
Collet	10N21	10N22	10N23	10N24
Collet Body	10N29	10N30	10N31	10N32
Gas Lens	45V29	45V24	45V25	45V26
Lg. Dia Gas Lens	45V0204		45V116	45V64
Stubby Collet		10N22S	10N23S	10N24S
Stubby Collet Body			17CB20	

Chart B: Gas Nozzles, HPN - High Performance Nozzles Available

SIZE	4	5	6	7	8	10	12	SHORT
Alumina	10N50	10N49	10N48	10N47 •	10N46 •	10N45	10N44	
Alumina Gas Lens	54N18	54N17	54N16	54N15 •	54N14 •			54N19*
Large Diameter Gas Lens			57N75		57N74	53N88 •	53N87 •	53N89*
Long Alumina		10N49L	10N48L	10N47L				
Long Gas Lens		54N17L	54N16L	54N15L				
Lava	105243	105242	105244	105245	08N78	08N79	08N80	
Long Lava	12N03	105260	12N02	105261				
Stubby Alumina	13N08	13N09	13N10 •	13N11 •	13N12	13N13		

Item No.	Part No.	Description
1	WP-17	Torch body, includes cup gasket (70°)
1A	18-7	Insert
2	57Y02	Long back cap, includes 98W18 O-ring
3	57Y04	Short back cap, includes 98W18 O-ring
4	18CG	Cup gasket
5	-	Collet (See chart A)
6	-	Collet body (See chart A)
7	-	Alumina nozzle (See chart B)
8	54N63	Large diameter gas lens insulator
9	-	Large diameter gas lens (See chart A)
10	-	Lg. diameter gas lens nozzle (See chart B)
11	54N01	Gas lens insulator
12	-	Gas lens (See chart A)
13	-	Alumina gas lens nozzle (See chart B)
14	-	Lava nozzle (See chart B)
15	18CG20	Stubby gasket
16	-	Stubby collet (See chart A)
17	17CB20	Stubby collet body (See chart A)
18	-	Stubby alumina nozzle (See chart B)
19	-	Long lava nozzle (See chart B)
20	105Z57	Power cable adapter
21	H-100	Handle (smooth, optional)
22	V-92-1	Front handle
23	V-92-2	Valve body
24	V-92-3	Rear handle
	V-92	Valve assy. includes items 22, 23, 24
25	-	Power cable - 1 piece
	57Y01	12-1/2 ft. (3.8 m) vinyl
	57Y03	25 ft. (7.6 m) vinyl
	57Y01R	12-1/2 ft. (3.8 m) rubber
	57Y03R	25 ft. (7.6 m) rubber
26	-	Power cable - 2 piece <b>Gas hose only</b>
	57Y01-2	12-1/2 ft. (3.8 m) 45V09R
	57Y03-2	25 ft. (7.6 m) 45V10R
27	WP-17V	Torch body, includes cup gasket and valve stem (70°)
27A	WP-17VN	Torch body, same as WP-17V, with 90° head
28	VS-2	Valve stem, includes 98W77 O-ring
29	H-100R	Handle (ribbed, standard)
		<b>Cable Repair Kits</b>
	ZCRK17	One-piece power cable repair kit
	ZCRK17-2	Two-piece power cable repair kit

**Cable Covers:** WC-3-10, WC-3-22  
**Extension Kit:** EK-2-25-R  
**Quick Connect:** ADD Q in front of torch package or cable #  
**Weight:** 6 oz. (less power cable)  
**Torch Length:** 7-3/4"

\* Not recommended for use with high frequency current  
• HPN nozzle available

**Model WP-18 / 18V / 18SP / Water Cooled Tig Torches / 350 AMPS**



Part No.	Description	Max Amps	Head Angle	Gas Valve	Handle Style	Access Kit	Hook-Up Kit	Cable
WP-18 WP-18-12 WP-18-25	Torch Body Torch Package Torch Package	350	70°	No	Textured 1-1/16 Dia.	AK-3	HK-1	3-Piece Vinyl Power Cable
WP-18V WP-18V-12 WP-18V-25	Torch Body Torch Package Torch Package	350	70°	Knob & Stem	Textured 1-1/16 Dia.	AK-3	HK-1	3-Piece Vinyl Power Cable
WP-18SP WP-18SP-12 WP-18SP-25	Torch Body Torch Package Torch Package	350	180°	No	Textured 1-1/16 Dia.	AK-3	HK-1	3-Piece Vinyl Power Cable

**Work horse torches for continuous duty**

**WP-18:** Heavy duty rugged production torch for continuous duty to 350 amps. **WP-18SP:** Pencil Style.

Parts interchange with WP-17, WP-17V, WP-26, WP-26V

Torch Models. **WP-18V:** model available with built-in fingertip gas control valve.

**Torch bodies only include cup gasket**

**Torch packages include:** Torch body, handle, long back cap, power cable and hoses. Power cable adapter must be ordered separately.

**Water Cooling Requirements:** 1 quart per minute at maximum of 50 PSI pressure

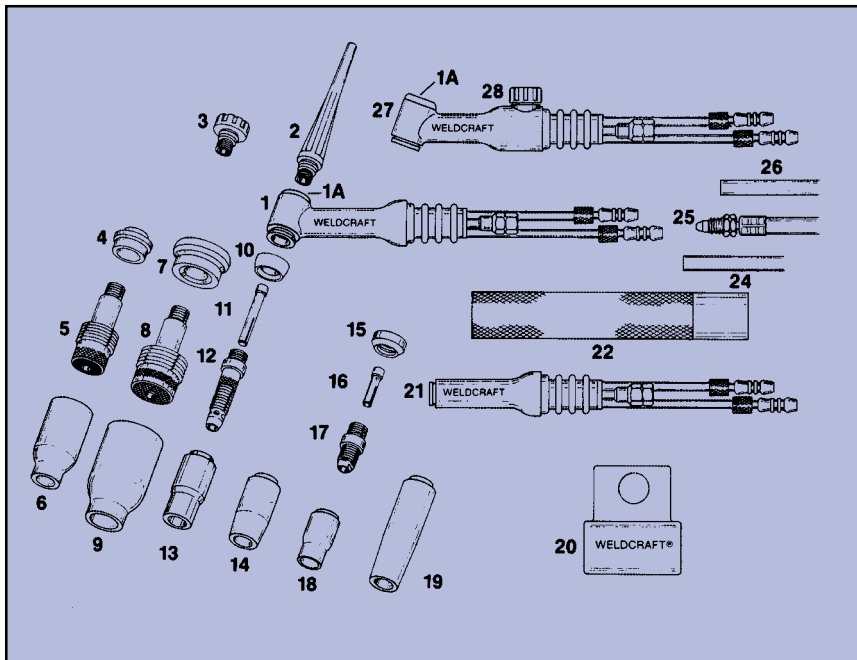

Item No.	Part No.	Description
1	WP-18	Torch body, includes cup gasket (70°)
1A	18-7	Insert
2	57Y02	Long back cap, includes 98W18 O-ring
3	57Y04	Short back cap, includes 98W18 O-ring
4	54N01	Gas lens insulator
5	-	Gas lens (See chart A)
6	-	Alumina gas lens nozzle (See chart B)
7	54N63	Lg. diameter gas lens insulator
8	-	Lg. diameter gas lens (See chart A)
9	-	Lg. diameter gas lens nozzle (See chart B)
10	18CG	Cup gasket
11	-	Collet (See chart A)
12	-	Collet body (See chart A)
13	-	Alumina nozzle (See chart B)
14	-	Lava nozzle (See chart B)
15	18CG20	Stubby gasket
16	-	Stubby collet (See chart A)
17	-	Stubby collet body (See chart A)
18	-	Stubby alumina nozzle (See chart B)
19	-	Long lava nozzle (See chart B)
20	45V11	Power cable adapter
21	WP-18SP	Pencil torch body, includes cup gasket
22	H-200	Handle (smooth, standard on WP-18, 18SP)
24	-	Water hose
		40V74 12-1/2 ft. (3.8 m), 40V74R- Rubber
		41V32 25 ft. (7.6 m), 41V32R- Rubber
25	-	Power Cable
		40V64 12-1/2 ft. (3.8 m), 40V64R- Rubber
		41V29 25 ft. (7.6 m), 41V29R- Rubber
26	-	Gas hose
		40V75 12-1/2 ft. (3.8 m), 40V75R18- Rubber
		41V30 25 ft. (7.6 m), 41V30R18- Rubber
27	WP-18V	Valve torch body, includes cup gasket and valve stem (70°)
28	VS-2	Valve stem, includes 98W77 O-ring
		<b>Cable Repair Kits</b>
	ZCRK-18	Power cable repair kit
	ZHRKG-18	Gas hose repair kit
	ZHRKW-18	Water hose repair kit

**Chart A: Collets, Collet Bodies, Gas Lens**

Electrode Diameter	.020	.040	1/16	3/32	1/8	5/32
Collet	10N21	10N22	10N23	10N24	10N25	54N20
Collet Body	10N29	10N30	10N31	10N32	10N28	406488
Gas Lens	45V29	45V24	45V25	45V26	45V27	45V28
Lg. Dia. Gas Lens	45V0204		45V116	45V64	995795	45V63
Stubby Collet		10N22S	10N23S	10N24S	10N25S	
Stubby Collet Body			17CB20			

**Chart B: Gas Nozzles, HPN - High Performance Nozzles Available**

SIZE	4	5	6	7	8	10	12	SHORT
Alumina	10N50	10N49	10N48	10N47 •	10N46 •	10N45	10N44	
Alumina Gas Lens	54N18	54N17	54N16	54N15 •	54N14 •			54N19*
Large Diameter Gas Lens			54N75		57N74	53N88 •	53N87 •	53N89*
Long Alumina		10N49L	10N48L	10N47L				
Long Gas Lens		54N17L	54N16L	54N15L				
Lava	105Z43	105Z42	105Z44	105Z45	08N78	08N79	08N80	
Long Lava	12N03	105Z60	12N02	105Z61				
Stubby Alumina	13N08	13N09	13N10 •	13N11 •	13N12	13N13		

**Cable Covers:** WC-3-10, WC-3-22  
**Extension Kit:** EK-1-25  
**Quick Connect:** ADD Q in front of torch package or cable #  
**Weight:** 7 oz. (less hoses)  
**Torch Length:** 9-1/4"

\* Not recommended for use with high frequency current  
 • HPN nozzle available

**Model WP-18P / Water Cooled Tig Torch / 500 AMPS**



**Work horse torches for continuous duty**

**WP-18P:**

Machine torch for a variety of mechanized applications.

Part No.	Description	Max Amps	Head Angle	Gas Valve	Handle Style	Access Kit	Hook-Up Kit	Cable
WP-18P	Torch Body	500	180°	No	Barrel	N/A	HK-1	3-Piece Vinyl Power Cable
WP-18P-12	Torch Package							
WP-18P-25	Torch Package							

**Torch bodies only include cup gasket**

**Torch packages include:** Torch body, handle, long back cap, and power cable and hoses.

Power cable adapter must be ordered separately.

For torch package with rack: add pitch after 18P. ex. WP-18P24-12 (w/ 24 pitch rack)

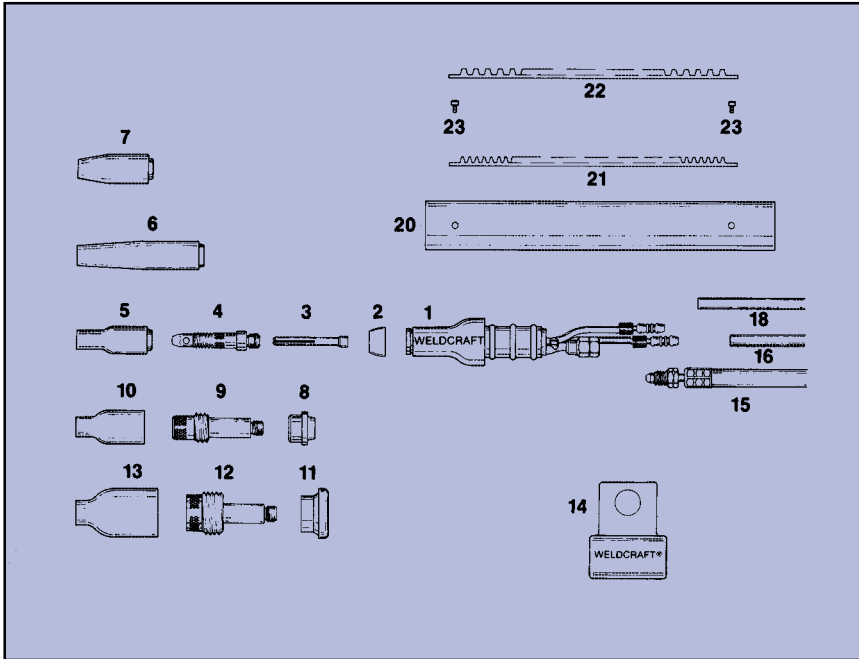

**Chart A: Collets, Collet Bodies, Gas Lens**

Electrode Diameter	.020	.040	1/16	3/32	1/8	5/32
Collet	10N21	10N22	10N23	10N24	10N25	54N20
Collet Body	10N29	10N30	10N31	10N32	10N28	406488
Gas Lens	45V29	45V24	45V25	45V26	45V27	45V28
Lg. Dia. Gas Lens	45V0204		45V116	45V64	995795	45V63

Water Cooling Requirements: 1 quart per minute at maximum of 50 PSI pressure

**Chart B: Gas Nozzles, HPN - High Performance Nozzles Available**

SIZE	4	5	6	7	8	10	12	SHORT
Alumina	10N50	10N49	10N48	10N47 •	10N46 •	10N45	10N44	
Alumina Gas Lens	54N18	54N17	54N16	54N15 •	54N14 •			54N19*
Large Diameter Gas Lens			57N75		57N74	53N88 •	53N87 •	53N89*
Long Alumina		10N49L	10N48L	10N47L				
Long Gas Lens		54N17L	54N16L	54N15L				
Lava	105Z43	105Z42	105Z44	105Z45	08N78	08N79	08N80	
Long Lava	12N03	105Z60	12N02	105Z61				

Item No.	Part No.	Description
1	WP-18P	Torch body, includes cup gasket (180°)
2	18CG	Cup gasket
3	—	Collet (See chart A)
4	—	Collet body (See chart A)
5	—	Alumina nozzle (See chart B)
6	—	Long lava nozzle (See chart B)
7	—	Lava nozzle (See chart B)
8	54N01	Insulator
9	—	Gas lens (See chart A)
10	—	Alumina gas lens nozzle (See chart B)
11	54N63	Lg. diameter gas lens insulator
12	—	Lg. diameter gas lens (See chart A)
13	—	Lg. diameter gas lens nozzle (See chart B)
14	45V11	Power cable adapter
15	—	Power cable
		40V64P 12-1/2 ft. (3.8 m), 40V64PR - Rubber
		41V29P 25 ft. (7.6 m), 41V29PR - Rubber
16	—	Water hose
		40V74 12-1/2 ft. (3.8 m), 40V74R - Rubber
		41V32 25 ft. (7.6 m), 41V32R - Rubber
18	—	Gas hose
		40V75 12-1/2 ft. (3.8 m), 40V75R18 - Rubber
		41V30 25 ft. (7.6 m), 41V30R18 - Rubber
20	18PB	Barrel (10" lg. x 1-3/8" dia.) with screwholes
	18PBWH	Barrel without screwholes
	18R32	Rack, 32 pitch (optional)
	18R24	Rack, 24 pitch (optional)
	18R-1	Screw (2 required)
		<b>Cable Repair Kits</b>
	ZCRK-18	Power cable repair kit
	ZHRKG-18	Gas hose repair kit
	ZHRKW-18	Water hose repair kit

**Cable Covers:** WC-3-10, WC-3-22  
**Extension Kit:** EK-1-25  
**Quick Connect:** ADD Q. in front of torch package or cable #  
**Torch Length:** 12-1/2"

\* Not recommended for use with high frequency current  
 • HPN nozzle available

**Model WP-18SC / Water Cooled Tig Torch / 400 AMPS**



**Super Cool 18® Tig Torch**

Weldcraft's Super Cool 18 solves the age-old problem of overheating associated with 18 style 350 amp water-cooled torches. Its unique patented water cooling chamber eliminates overheating, softening, twisting and buckling of the collet, which generally occurs when welding with AC current on aluminum alloys.

The water cooling chamber design ensures water flow over the entire length of the head, keeping the collet and nose collet body cool. The gas nozzle is now screwed onto the water chamber sleeve so it will remain cooler for longer service.

Part No.	Description	Max Amps	Head Angle	Gas Valve	Handle Style	Access Kit	Hook-Up Kit	Cable
WP-18SC	Torch Body	400	70°	No	Textured 1-1/16 Dia.	AK-18	HK-1	3-Piece Vinyl Power Cable
WP-18SC-12	Torch Package							
WP-18SC-25	Torch Package							

Torch bodies only include nozzle gasket

Torch packages include: Torch body, handle, long back cap, and power cable assembly. Power cable adapter must be ordered separately.

Water Cooling Requirements: 1 quart per minute at maximum of 50 PSI pressure

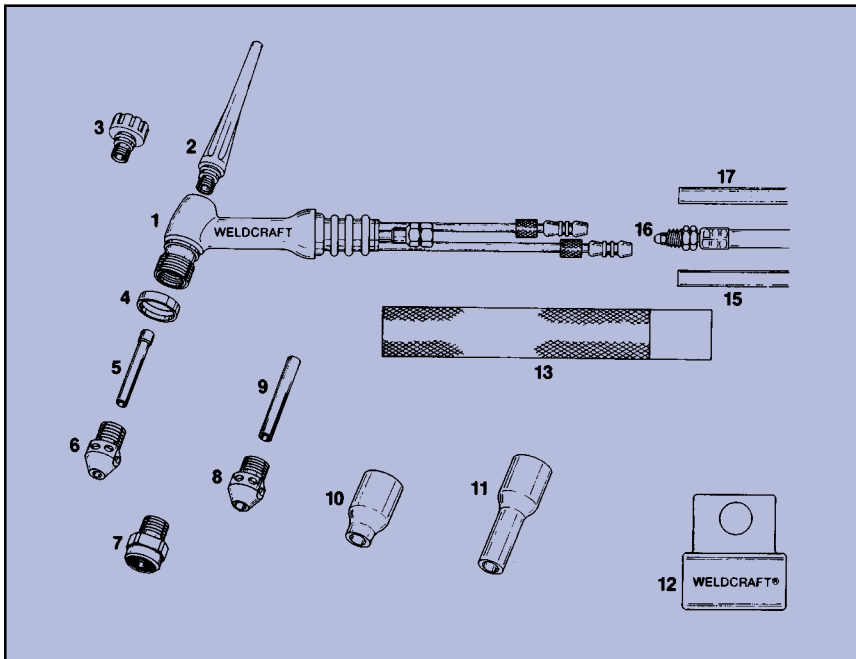

Item No.	Part No.	Description
1	WP-18SC	Torch body, includes nozzle gasket (70°)
2	57Y02	Long back cap, includes 98W18 O-ring
3	57Y04	Short back cap, includes 98W18 O-ring
4	18NG	Nozzle gasket
5	-	Standard collet (See chart A)
6	-	Std. nose collet body (See chart A)
7	-	Gas lens (See chart A)
8	-	H.D. nose collet body (See chart A)
9	-	Heavy-duty collet (See chart A)
10	-	Alumina nozzle (See chart B)
11	-	Long alumina nozzle (See chart B)
12	45V11	Power cable adapter
13	H -200	Handle
		Water hose
		40V74 12-1/2 ft. (3.8 m), 40V74R -Rubber
		41V32 25 ft. (7.6 m), 41V32R -Rubber
		Power Cable
		40V64 12-1/2 ft. (3.8 m), 40V64R -Rubber
		41V29 25 ft. (7.6 m), 41V29R -Rubber
		Gas hose
		40V75 12-1/2 ft. (3.8 m), 40V75R18 -Rubber
		41V30 25 ft. (7.6 m), 41V30R18 -Rubber
		<b>Cable Repair Kits</b>
	ZCRK-18	Power cable repair kit
	ZHRKG-18	Gas hose repair kit
	ZHRKW-18	Water hose repair kit

**Chart A: Collets, Collet Bodies, Gas Lens**

Electrode Diameter	.020	.040	1/16	3/32	1/8	5/32	3/16
Standard Collet	10N21	10N22	10N23	10N24	10N25	54N20	
Heavy-duty Collet					10N25HD	54N20HD	18C36
Gas Lens	18GL02	18GL04	18GL16	18GL32	18GL18	18GL53	18GL36
Std Nose Collet Body	NCB-53						
H.D Nose Collet Body							NCB-36*

\* Use only with heavy duty collets.

Water cooled torches require cooling water flow of 1 quart (.94 liter) to 1-1/2 quarts (1.4 liters) per minute at a maximum of 50 PSI pressure

**Chart B: Gas Nozzles, HPN - High Performance Nozzles Available**

SIZE	4	5	6	7	8	SHORT
Alumina	54N18	54N17	54N16	54N15 •	54N14 •	54N19*
Long Alumina		54N17L	54N16L	54N15L		

\* Not recommended for use with high frequency current

• HPN nozzle available

**Cable Covers:** WC-3-10, WC-3-22  
**Extension Kit:** EK-1-25  
**Quick Connect:** ADD Q in front of torch package or cable #  
**Torch Length:** 9-1/4"

**Model WP-20 / WP-20V (250 AMPS) / WP-20P (225 AMPS) / WP-25 (200 AMPS) / Water Cooled Tig Torches**



**Lightweight, small durable torches**

Compact and well-balanced for general duty use. Efficient around the head cooling for trouble free performance and long life. Parts interchange with WP-9, WP-9P and WP-25 Models.

Part No.	Description	Max Amps	Head Angle	Gas Valve	Handle Style	Access Kit	Hook-Up Kit	Cable
WP-20 WP-20-12 WP-20-25	Torch Body Torch Package Torch Package	250	70°	No	Textured 3/4 Dia.	AK-4	HK-1	3-Piece Vinyl Power Cable
WP-20V WP-20V-12 WP-20V-25	Torch Body Torch Package Torch Package	250	70°	Knob & Stem	Textured 3/4 Dia.	AK-4	HK-1	3-Piece Vinyl Power Cable
WP-20P WP-20P-12 WP-20P-25	Torch Body Torch Package Torch Package	225	180°	No	Textured 3/4 Dia.	AK-4A	HK-1	3-Piece Vinyl Power Cable
WP-25 WP-25-12 WP-25-25	Torch Body Torch Package Torch Package	200	180° FLEX	No	Textured 3/4 Dia.	AK-4A	HK-1	3-Piece Vinyl Power Cable

Torch bodies only include cup gasket

Torch packages include: Torch body, handle, medium back cap, and power cable assembly.

Power cable adapter must be ordered separately. WP-20P torch does not use back caps.

Water Cooling Requirements: 1 quart per minute at maximum of 50 PSI pressure

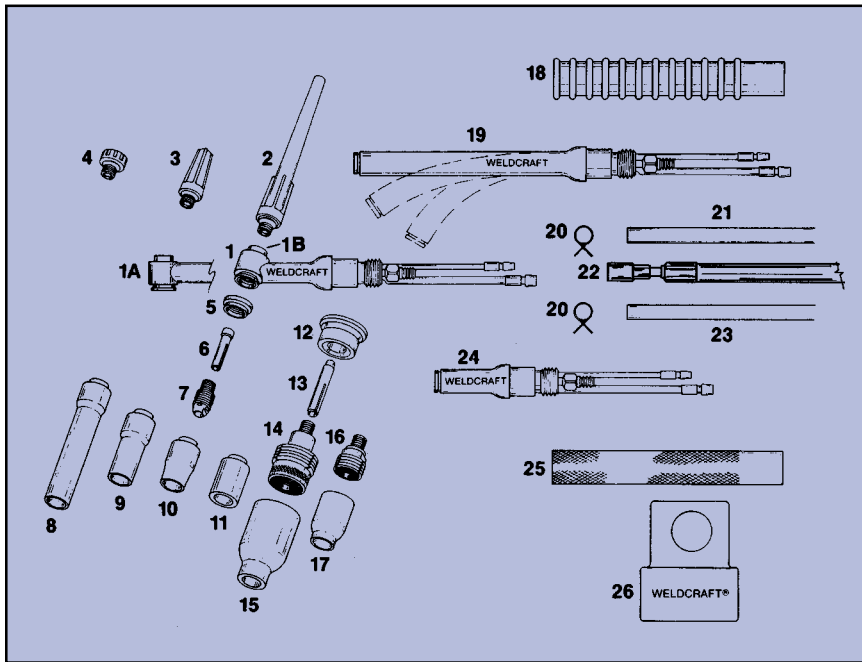

Item No.	Part No.	Description
1	WP-20	Torch body, includes cup gasket (70°)
1A	WP-20N	Torch body, same as WP-20, with 90° head
1B	09-4	Insert
2	41V24	Long back cap, includes 98W77 O-ring
3	41V35	Medium back cap, includes 98W77 O-ring
4	41V33	Short back cap, includes 98W77 O-ring
5	598882	Cup gasket
6	-	Collet (See chart A)
7	-	Collet body (See chart A)
8	-	Extra long lava nozzle (See chart B)
9	-	Long lava nozzle (See chart B)
10	-	Alumina nozzle (See chart B)
11	-	Lava nozzle (See chart B)
12	54N63-20	Lg. diameter gas lens insulator
13	-	Lg. diameter gas lens collet (See chart A)
14	-	Lg. diameter gas lens (See chart A)
15	-	Lg. diameter gas lens nozzle (See chart B)
16	-	Gas lens (See chart A)
17	-	Alumina gas lens nozzle (See chart B)
18	53N06R	Handle (ribbed, optional)
19	WP-25	Flexible torch body, includes cup gasket
20	53N04	Hose clamp
21	-	Gas hose 45V09 12-1/2 ft. (3.8 m), 45V09R -Rubber 45V10 25 ft. (7.6 m), 45V10R -Rubber
22	-	Power Cable 45V03 12-1/2 ft. (3.8 m), 45V03R, 45V03HD 45V04 25 ft. (7.6 m), 45V04R, 45V04HD
23	-	Water hose 45V07 12-1/2 ft. (3.8 m), 45V07R, 45V07HD 45V08 25 ft. (7.6 m), 45V08R, 45V08HD
24	WP-20P	Pencil torch body, includes cup gasket
25	53N06	Handle (smooth, standard)
26	45V11	Power cable adapter
		<b>Cable Repair Kits</b> ZCRK-20 Power cable repair kit ZHRKG-20 Gas hose repair kit ZHRKW-20 Water hose repair kit VS-2 Valve stem, includes 98W77 O-ring (not shown)

Chart A: Collets, Collet Bodies, Gas Lens

Electrode Diameter	.020	.040	1/16	3/32	1/8
Collet	13N20	13N21	13N22	13N23	13N24
Collet Body	13N25	13N26	13N27	13N28	13N29
Gas Lens	45V41	45V42	45V43	45V44	45V45
Lg. Dia Gas Lens Collet	13N20L	13N21L	13N22L	13N23L	13N24L
Lg. Dia Gas Lens	45V0204S		45V116S	45V64S	995795S

Chart B: Gas Nozzles, HPN - High Performance Nozzles Available

SIZE	3	4	5	6	7	8	10	12	SHORT
Alumina		13N08	13N09	13N10 •	13N11 •	13N12	13N13		
Alumina Gas Lens		53N58 •	53N59 •	53N60 •	53N61 •	53N61S •			
Large Diameter Gas Lens				57N75		57N74	53N88	53N87	53N89*
Lava		13N14	13N15	13N16	13N17	13N18	13N19		
Long Lava**	796F70	796F71	796F72	796F73					
Ex. Long Lava	796F74	796F75	796F76	796F77					

**Cable Covers:** WC-3-10, WC-3-22  
**Extension Kit:** EK-1-25  
**Quick Connect:** ADD Q in front of torch package or cable #  
**Weight WP-20:** 3 oz. (less hoses)  
**Weight WP-25:** 4 oz. (less hoses)  
**Torch Length:** WP-20: 7"  
 WP-20P: 6-1/2"  
 WP-25: 11"

\* Not recommended for use with high frequency current

\*\* Also available in alumina. Ex: A796F70

• HPN nozzle available

**Model WP-22 / Water Cooled Machine Torch / 250 AMPS**



**Features:**

Front or back loading of the tungsten electrode. Torch does not need to be moved to load or remove the electrode.

Front or back tightening of the electrode. The adjustment to tighten the electrode can be made with the ribbed sleeve at the nozzle end or by the knob at the back end of torch.

Standard collet bodies, gas lens collet bodies and gas cups interchange with the popular WP-20 manual torch.

Part No.	Description	Max Amps	Overall Length	Acc Kit	Hook-Up Kit
WP-22A WP-22A-3 WP-22A-12 WP-22A-25	Torch Head Torch Package Torch Package Torch Package	250	6-1/2"	N/A	HK-1
WP-22B WP-22B-3 WP-22B-12 WP-22B-25	Torch Head Torch Package Torch Package Torch Package	250	3-1/2"	N/A	HK-1

**Model A** uses 7" long tungsten electrodes  
**Model B** uses 3" long tungsten electrodes

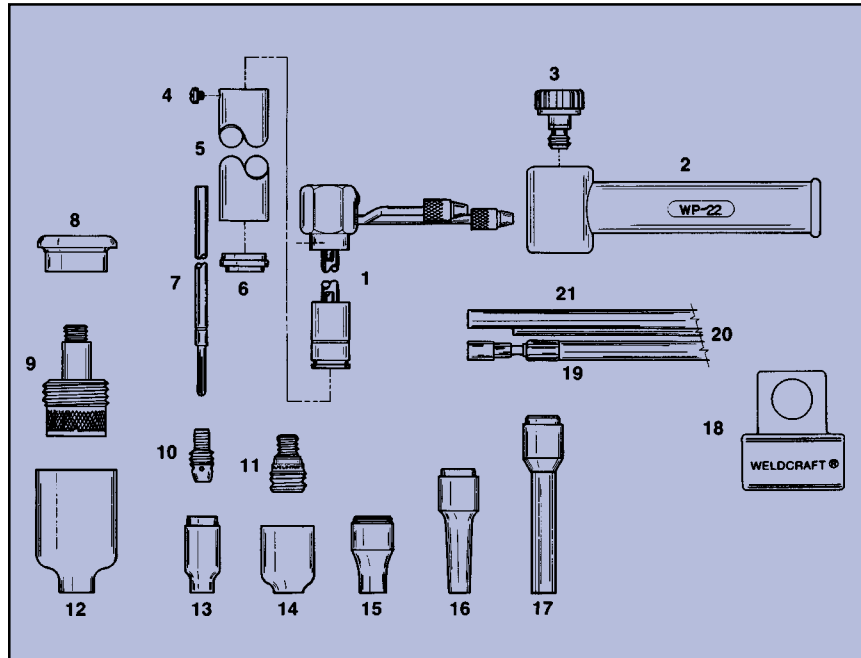

Item No.	Part No.	Description
1	WP-22A WP-22B	7" long torch body 3" long torch body
2	22-9	Insulating boot
3	22-7	Collet knob, includes 98W77 O-ring
4	18R-1	6-32 x 3/16" fillister head screw
5	22-8A 22-8B	7" barrel 3" barrel
6	22-10	Cup gasket
7	—	Collet (See chart A)
8	54N63-22	Lg. diameter gas lens insulator
9	—	Lg. diameter gas lens (See chart A)
10	—	Collet body (See chart A)
11	—	Gas lens (See chart A)
12	—	Lg. diameter gas lens nozzle (See chart B)
13	—	Alumina nozzle (See chart B)
14	—	Alumina gas lens nozzle (See chart B)
15	—	Lava nozzle (See chart B)
16	—	Long lava nozzle (See chart B)
17	—	Extra long lava nozzle (See chart B)
18	45V11	Power cable adapter
19	—	Power cable 45V03HD-L3 3 ft. (1.4 m) 45V03HD 12-1/2 ft. (3.8 m) 45V04HD 25 ft. (7.6 m)
20	—	Gas hose 45V09-L3 3 ft. (1.4 m) 45V09 12-1/2 ft. (3.8 m) 45V10 25 ft. (7.6 m)
21	—	Water hose 45V07HD-L3 3 ft. (1.4 m) 45V07HD 12-1/2 ft. (3.8 m) 45V08HD 25 ft. (7.6 m)
	ZCRK-20	<b>Cable Repair Kits</b> Power cable repair kit
	ZHRKG-20	Gas hose repair kit
	ZHRKW-20	Water hose repair kit

**Chart A: Collets, Collet Bodies, Gas Lens**

Electrode Diameter	.020	.040	1/16	3/32	1/8
Collet	22N20A 22N20B	22N21A 22N21B	22N22A 22N22B	22N23A 22N23B	22N24A 22N24B
Collet Body	13N25	13N26	13N27	13N28	13N29
Gas Lens	45V41	45V42	45V43	45V44	45V45
Lg. Dia. Gas Lens Collet	22N20AL 22N20BL	22N21AL 22N21BL	22N22AL 22N22BL	22N23AL 22N23BL	22N24AL 22N24BL
Lg. Dia. Gas Lens	45V0204S		45V116S	45V64S	995795S

Water cooled torches require cooling water flow of 1 quart (.94 liter) to 1-1/2 quarts (1.4 liters) per minute at a maximum of 50 PSI pressure.

**Chart B: Gas Nozzles, HPN - High Performance Nozzles Available**

SIZE	3	4	5	6	7	8	10	12	SHORT
Alumina		13N08	13N09	13N10 •	13N11 •	13N12	13N13		
Alumina Gas Lens		53N58 •	53N59 •	53N60 •	53N61 •	53N61S •			
Lg. Dia. Gas Lens				57N75		57N74	53N88 •	53N87 •	53N89*
Lava		13N14	13N15	13N16	13N17	13N18	13N19		
Long Lava**	796F70	796F71	796F72	796F73					
Ex. Long Lava	796F74	796F75	796F76	796F77					

\* Not recommended for use with high frequency current

\*\* Also available in alumina. Example A796F70

• HPN nozzle available

**Cable Covers:** WC-3-10, WC-3-22  
**Extension Kit:** EK-1-25  
**Quick Connect:** ADD Q. in front of torch package or cable #

## Model WP-24W / Water Cooled Tig Torch / 180 AMPS / Model WP-24 / Air Cooled Tig Torch / 80 AMPS



Note: If other than standard power cable is desired for air cooled torch, change last character to receive desired power cable.

- 1: One piece vinyl jacketed power cable
- 2: Two piece power cable
- R: One piece rubber jacketed power cable

### WP-24

#### Small, lightweight torch

Ideal for intricate work. Reaches into tight places. Handle mounted gas control valve available. Feather weight but well-balanced and durable.

Parts interchange with WP-24W Model.

Torch body head angle is available either 60° or 90°. 60° angle is standard.

Part No.	Description	Max Amps	Head Angle	Gas Valve	Handle Style	Access Kit	Hook-Up Kit	Cable
WP-24 WP-24-12-2 WP-24-25-2	Torch Body Torch Package Torch Package	80	60°	No	Textured 3/4 Dia.	AK-5	Call for Details	1-Piece Vinyl Power Cable
WP-24 WP-24-12V-2 WP-24-25V-2	Torch Body Torch Package Torch Package	80	60°	Slide	Smooth 3/4 Dia.	AK-5	Call for Details	1-Piece Vinyl Power Cable
WP-24W WP-24W-12 WP-24W-25	Torch Body Torch Package Torch Package	180	70°	No	Textured 3/4 Dia.	AK-5W	HK-1	1-Piece Vinyl Power Cable

Torch bodies only include insulating gasket

Torch Packages include: Torch body, handle, power cable assembly.

Power cable adapter must be ordered separately.

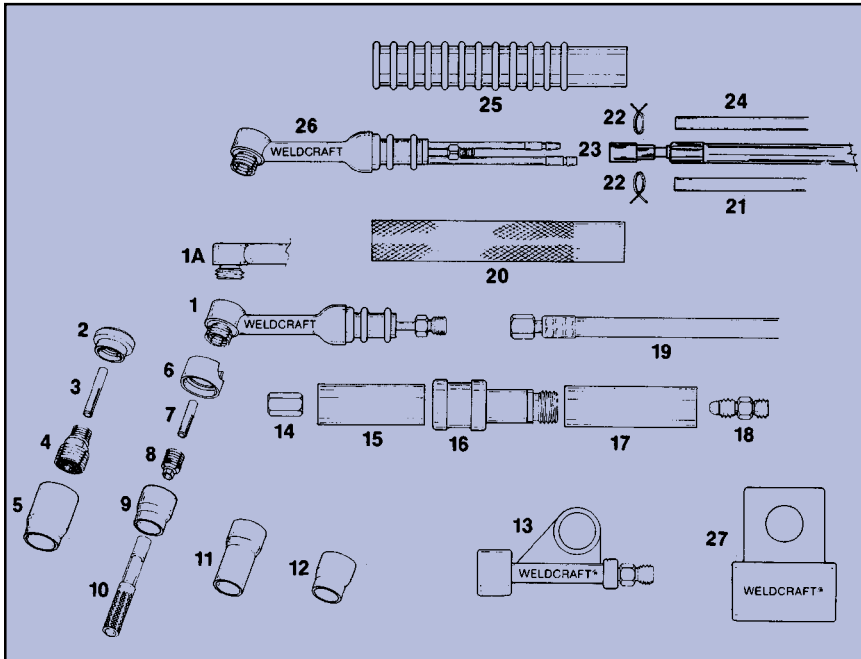

Item No.	Part No.	Description
1	WP-24	Torch body includes cup gasket (60°)
1A	WP-24N	Torch body same as WP-24, with 90° head
2	53N66	Gas lens insulator
3	-	Gas lens collet (See chart A)
4	-	Gas lens (See chart A)
5	-	Alumina gas lens nozzle (See chart B)
6	53N22	Cup gasket
7	-	Collet (See chart A)
8	-	Collet body (See chart A)
9	-	Lava nozzle (See chart B)
10	53N20	Collet body wrench
11	-	Long lava nozzle (See chart B)
12	-	Alumina nozzle (See chart B)
13	53N43	Power cable adapter (WP-24)
14	24 -4	Coupler
15	V-92-1	Front handle
16	V-92-2	Valve body
17	V-92-3	Rear handle
18	V-92	Valve assy. includes items 15, 16, 17
19	24 -5	Adapter
20	56Y38	Power cable (WP-24) 12-1/2 ft. (3.8 m) vinyl
21	56Y97	25 ft. (7.6 m) vinyl
22	56Y38R	12-1/2 ft. (3.8 m) rubber
23	56Y97R	25 ft. (7.6 m) rubber
24	H-100	Handle (smooth, standard)
25	45V07	Water hose (WP-24W) 12-1/2 ft. (3.8 m)
26	45V08	25 ft. (7.6 m)
27	53N04	Hose clamp
28	-	Power cable (WP-24W) 12-1/2 ft. (3.8 m)
29	45V03	25 ft. (7.6 m)
30	45V04	25 ft. (7.6 m)
31	-	Gas hose (WP-24W) 12-1/2 ft. (3.8 m)
32	45V09	25 ft. (7.6 m)
33	45V10	25 ft. (7.6 m)
34	H-100R	Handle (ribbed, optional)
35	WP-24W	Torch body, includes cup gasket (70°)
36	45V11	Power cable adapter (WP-24W)

Chart A: Collets, Collet Bodies, Gas Lens

Electrode Diameter	.020	.040	1/16	3/32
Collet	53N15	53N16	53N14	24C332
Collet Body	53N17	53N18	53N19	24CB332
Gas Lens Collet	53N62	53N63	53N64	24GLC332
Gas Lens	45V41	45V42	45V43	45V44

Water cooled torches require cooling water flow of 1 quart (.94 liter) to 1-1/2 quarts (1.4 liters) per minute at a maximum of 50 PSI pressure.

Chart B: Gas Nozzles, HPN - High Performance Nozzles Available

SIZE	.165	4	5	6	7	8
Alumina		A53N24	A53N25	A53N27		
Lava	53N23 •	53N24 •	53N25 •	53N27 •		
Long Lava		53N28		53N26		
Alumina Gas Lens		53N58 •	53N59 •	53N60 •	53N61 •	53N61S •

\* Not recommended for use with high frequency current

• HPN nozzle available

**Cable Covers:** WC-3-10, WC-3-22  
**Extension Kit:** Not Available  
**Quick Connect:** ADD Q in front of torch package or cable #  
**Weight WP-24:** 1 oz. (less power cable)  
**Weight WP-24W:** 3 oz. (less hoses)  
**Torch Length:** 7-1/2"

**Model WP-26 & WP-26V / Air Cooled Tig Torches / 200 AMPS**



Part No. WP-26

**Maximum capacity air cooled torch for continuous heavy-duty use**

Heavy copper construction for rugged field work. Heavy duty 2 pc. power cable and ribbed handle are standard equipment. Parts interchange with WP-18, WP-17 and WP-17V models.

Note: If other than standard power cable is desired for air cooled torch, change last character to receive desired power cable.  
-2: Two piece power cable  
-R: One piece rubber jacketed power cable  
(1 pc. vinyl power cable is not available)

Part No.	Description	Max Amps	Head Angle	Gas Valve	Handle Style	Access Kit	Hook-Up Kit	Cable
WP-26 WP-26-12-2 WP-26-25-2	Torch Body Torch Package Torch Package	200	70°	No	Ribbed 1-1/4 Dia.	AK-3	HK-3	2-Piece Power Cable
WP-26V WP-26V-12-2 WP-26V-25-2	Torch Body Torch Package Torch Package	200	70°	Knob & Stem	Ribbed 1-1/4 Dia.	AK-3	HK-2	2-Piece Power Cable

Torch bodies only include cup gasket  
Torch Packages include: Torch body, handle, long back cap, and power cable assembly.  
Power cable adapter is not needed on 2 piece power cable.

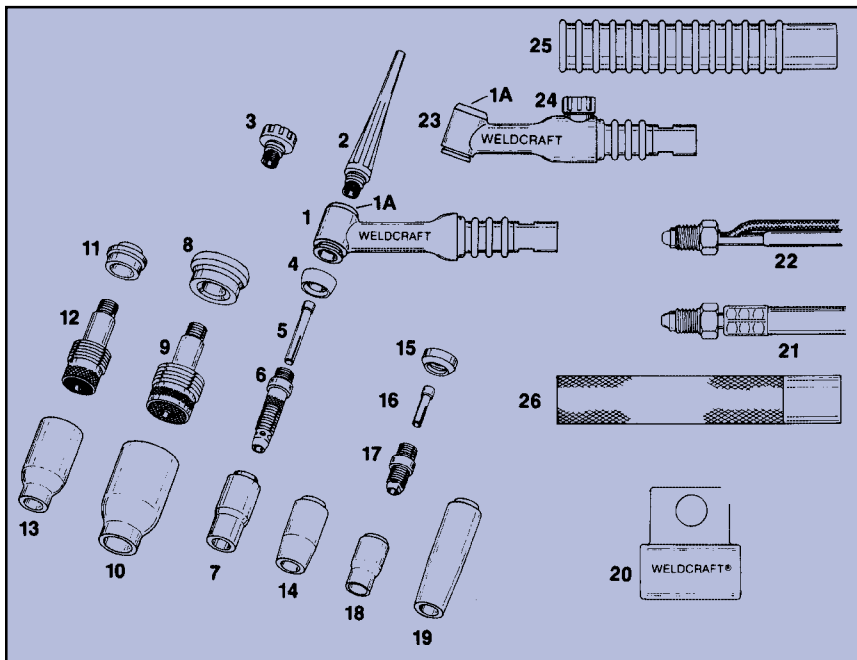

Chart A: Collets, Collet Bodies, Gas Lens

Electrode Diameter	.020	.040	1/16	3/32	1/8	5/32
Collet	10N21	10N22	10N23	10N24	10N25	54N20
Collet Body	10N29	10N30	10N31	10N32	10N28	406488
Gas Lens	45V29	45V24	45V25	45V26	45V27	45V28
Lg. Dia Gas Lens Collet	45V0204		45V116	45V64	995795	45V63
Stubby Collet		10N22S	10N23S	10N24S	10N25S	
Stubby Collet Body			17CB20			

Chart B: Gas Nozzles, HPN - High Performance Nozzles Available

SIZE	4	5	6	7	8	10	12	SHORT
Alumina	10N50	10N49	10N48	10N47 •	10N46 •	10N45	10N44	
Alumina Gas Lens	54N18	54N17	54N16	54N15 •	54N14 •			54N19*
Large Diameter Gas Lens			57N75		57N74	53N88	53N87	53N89*
Long Alumina		10N49L	10N48L	10N47L				
Long Gas Lens		54N17L	54N16L	54N15L				
Lava	105Z43	105Z42	105Z44	105Z45	08N78	08N79	08N80	
Long Lava	12N03	105Z60	12N02	105Z61				
Stubby Alumina	13N08	13N09	13N10 •	13N11 •	13N12	13N13		

\* Not recommended for use with high frequency current  
• HPN nozzle available

Item No.	Part No.	Description
1	WP-26	Torch body, includes cup gasket (70°)
1A	18-7	Insert
2	57Y02	Long back cap, includes 98W18 O-ring
3	57Y04	Short back cap, includes 98W18 O-ring
4	18CG	Cup gasket
5	-	Collet (See chart A)
6	-	Collet body (See chart A)
7	-	Alumina nozzle (See chart B)
8	54N63	Lg. diameter gas lens insulator
9	-	Lg. diameter gas lens (See chart A)
10	-	Lg. diameter gas lens nozzle (See chart B)
11	54N01	Gas lens insulator
12	-	Gas lens (See chart A)
13	-	Alumina gas lens nozzle (See chart B)
14	-	Lava nozzle (See chart B)
15	18CG20	Stubby gasket
16	-	Stubby collet (See chart A)
17	-	Stubby collet body (See chart A)
18	-	Stubby alumina nozzle (See chart B)
19	-	Long lava nozzle (See chart B)
20	45V62	Power cable adapter
21	-	Power cable - 1 piece rubber 46V28R 12-1/2 ft. (3,8 m) 46V30R 25 ft. (7,6 m)
22	-	Power cable - 2 piece 46V28-2 12-1/2 ft. (3,8 m) 40V75R 46V30-2 25 ft. (7,6 m) 41V30R
23	WP-26V	Valve torch body, includes cup gasket and valve stem (70°)
24	VS-1	Valve stem, includes 98W77 O-ring
25	H-200R	Handle (ribbed, standard)
26	H-200	Handle (smooth, optional)
		<b>Cable Repair Kits</b>
	ZCRK26	One-piece power cable repair kit
	ZCRK26-2	Two-piece power cable repair kit

Cable Covers: WC-3-10, WC-3-22  
Extension Kit: Not available  
Quick Connect: ADD Q in front of torch package or cable #  
Weight: 10 oz. (less power cable)  
Torch Length: 8-1/2"

## Model WP-27 / Water Cooled Tig Torch / 500 AMPS



### Features:

Front or back loading of the tungsten electrode. Torch does not need to be moved to load or remove the electrode.

Front or back tightening of the electrode. The adjustment to tighten the electrode can be made with the ribbed sleeve at the nozzle end or by the knob at the back end of torch.

Internal tungsten adjustment. The electrode can be raised or lowered within the torch for extremely fine positioning. Axial movement of approximately 1/4" is possible.

Collet body has integral replaceable gas lens screens.

Part No.	Description	Max Amps	Barrell Diameter	Overall Length	Acc Kit	Hook-Up Kit
WP-27A WP-27A-3 WP-27A-12 WP-27A-25	Torch Head Torch Package w/ bracket assembly Torch Package Torch Package	500	1-3/8	9"	AK-27	HK-1
WP-27B WP-27B-3 WP-27B-12 WP-27B-25	Torch Head Torch Package w/ bracket assembly Torch Package Torch Package	500	1-3/8	20"	AK-27	HK-1

Cooling requirements: 2 qt./min. (1.9 L/ min) Maximum Pressure 50 PSI (345 kPa)  
Electrode Capacity .040" - 1/4" Dia. (1,0 - 6,4 mm)

Torch Packages include: body assembly, barrel, shaft assembly, insulating boot, cable and hoses.

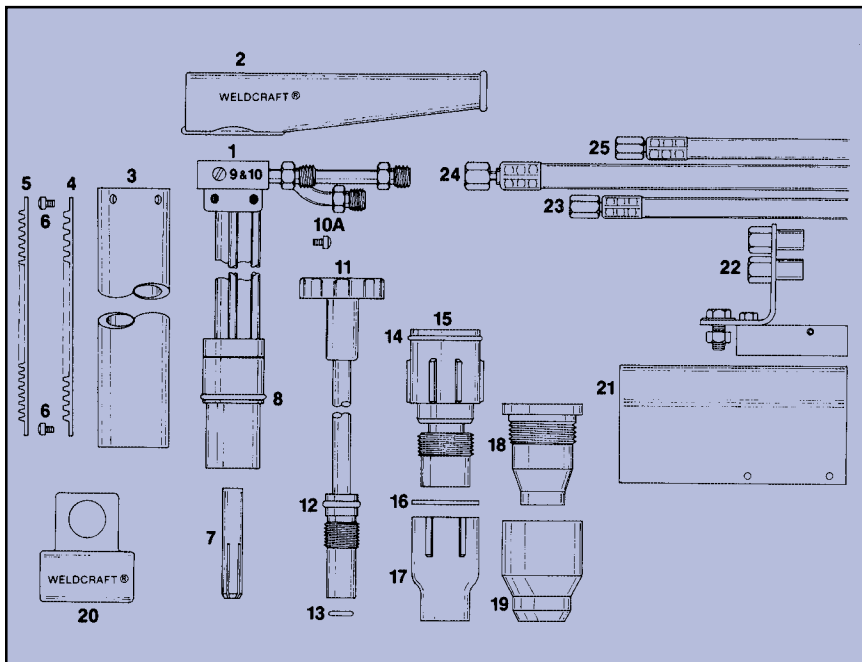

Chart A: Collets, Gas Lens

Electrode Diameter	.040	1/16	3/32	1/8	5/32	3/16	1/4
Collet	57N45	57N46	57N47	57N48	57N49	57N50	57N51
Gas Lens	49V22	49V23	49V24	49V25	49V26	49V27	49V28

Chart B: Gas Nozzles, HPN - High Performance Nozzles Available

SIZE	6	8	10	12	SHORT*
Alumina	57N75	57N74	53N88 •	53N87 •	53N89
Metal**			57N78	57N77	

\* Not recommended for use with high frequency current.

\*\* Requires 57N76 adapter.

• HPN nozzle available

Cable Covers: WC-4-10, WC-4-22  
Extension Kit: Not available  
Quick Connect: ADD Q in front of torch package or cable #

Item No.	Part No.	Description
1	WP-27A	Torch body, (9" long) includes shaft assy, barrel & boot
	WP-27B	Torch body, (20" long) includes shaft assy, barrel & boot
2	27-12	Insulating boot
3	27-10A	Barrel assy. "A" model, includes 3 ea. 27-10 screw, 3 ea. 27-11 washer
	27-10B	Barrel assy. "B" model, includes 3 ea. 27-10 screw, 3 ea. 27-11 washer
	27-9B	Barrel assy. w/rack hole
4	27R24	Barrel rack "B" model only, 24 pitch (1/4" x 1/4" x 11")
5	27R32	Barrel rack "B" model only, 32 pitch (1/4" x 1/4" x 11")
6	18R-1	6-32 x 3/16" fillister head screw
7	-	Collet (See chart A)
8	27-2-4	O-ring
10	27-10	6-32 x 5/16" binding head screw
10A	27-19	6-32 x 5/16" binding head nylon screw
11	27-13A	Shaft assy. "A" model includes shaft, knob, 1 ea. 27-13-2 & 27-13-3 O-ring
	27-13B	Shaft assy. "B" model includes shaft, knob, 1 ea. 27-13-2 & 27-13-3 O-ring
12	27-13-2	O-ring
13	27-13-3	O-ring
14	181W89	O-ring
15	-	57WCNA Water cooled nozzle (not shown) Gas lens (See chart A), includes 1 ea. 181W89 O-ring, 1 ea. 57N56 gasket
16	57N56	Gasket
17	-	Alumina nozzle (See chart B)
18	57N76	Metal nozzle adapter
19	-	Metal nozzle (See chart B)
20	45V11	Power cable adapter
21	27-18-3	Bracket insulating cover
22	27-18	Bracket assy. * includes bracket, insulator block, insulator cover, mounting hardware: 2 ea. 1/4"-20 X 3/4" hex hd. brass cap screw 1 ea. 1/2"-13 x 1" hex hd. brass cap screw 1 ea. 1/2"-13 hex brass nut 1 ea. 1/2" med. steel lock washer 1 ea. 1/2" plain brass washer
23	-	Gas hose 40V82R-3 3 ft. (9 m) 40V82R 12-1/2 ft. (3.8 m) 40V82RL 25 ft. (7.6 m)
24	-	Power cable 40V84R-3 3 ft. (9 m) 40V84R 12-1/2 ft. (3.8 m) 40V84RL 25 ft. (7.6 m)
25	-	Water-in hose 40V83R-3 3 ft. (9 m) 40V83R 12-1/2 ft. (3.8 m) 40V83RL 25 ft. (7.6 m)

\* Bracket assy. used on 3 ft. torch package only.

**Model WP-50 / Air Cooled Tig Torch / 50 AMPS / Model MT-125 / Micro Tig Torch / 125 AMPS**



**Cable Covers:** WC-3-10, WC-3-22  
**Extension Kit:** Not Available  
**Quick Connect:** ADD Q in front of torch package or cable #  
**Weight:** 1 oz. (less power cable)  
**Torch Length:** 8-1/2"

Part No.	Description	Max Amps	Head Angle	Gas Valve	Handle Style	Access Kit	Hook-Up Kit	Cable
WP-50 WP-50-12-2 WP-50-25-2	Torch Body Torch Package Torch Package	50	80° (180° Opt.)	No	Textured 3/4 Dia.	AK-6	HK-3	1-Piece Vinyl Power Cable
WP-50V WP-50V-12-2 WP-50V-25-2	Torch Body Torch Package Torch Package	50	80° (180° Opt.)	Knob & Stem	Textured 3/4 Dia.	AK-6	HK-2	1-Piece Vinyl Power Cable

**Torch bodies only include insulating gasket**  
**Torch Packages include:** Torch body, handle, power cable assembly.  
 Power cable adapter must be ordered separately (Part No. 105Z57).

Item No.	Stock No.	Description
1	150TB	Torch body
2	150VTB	Valve torch body, includes VS-2 valve stem
3	VS-2	Valve stem, includes 98W77 O-ring
4	50B81	Main tube (std. length 3-1/2")
5	50B81-2	Nut
6	50B82	Rubber sleeve (std. length 3-1/2")
7	50B180	Torch head (180°)
8	50B80	Torch head (80°)
9	50C20	Chuck, .020" (.5mm)
	50C40	Chuck, .040" (1mm)
10	50N04	Lava nozzle No. 4 (1/4")
12	53N20	Chuck wrench
13	105Z55	Handle
14		Power cable 57Y01-50 12-1/2 ft. (3.8m) 57Y03-50 25 ft. (7.6m)
15	105Z57	Power cable adapter
		Cable Repair Kit
	ZCRK17	One-piece power cable repair kit

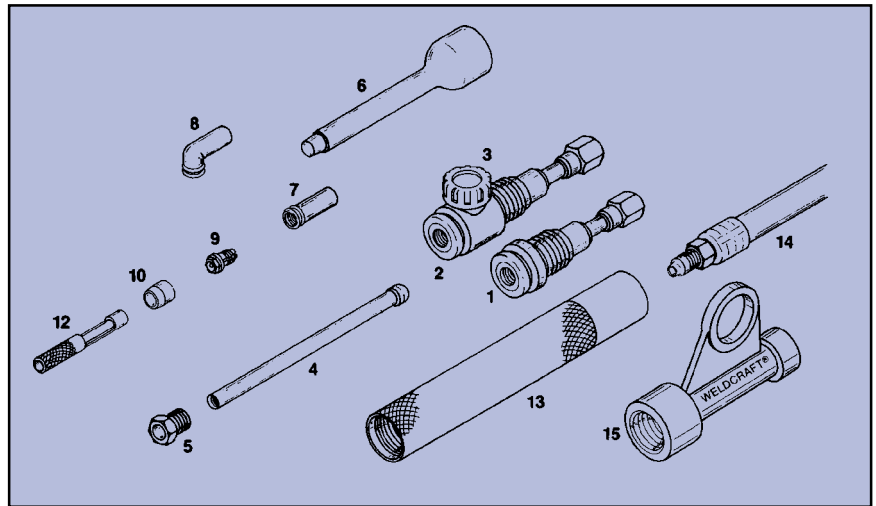

**MT-125**

**125 Amp Water Cooled Micro Tig Torch**

- MT-125 Torch body
- MT-125-12 Torch package with 12-1/2' leads
- MT-125-25 Torch package with 25' leads
- MT-125S Short torch body
- MT-125S-12 Torch package with 12-1/2' leads
- MT-125S-25 Torch package with 25' leads
- MT-125L Long torch body
- MT-125L-12 Torch package with 12-1/2' leads
- MT-125L-25 Torch package with 25' leads

**Features:**

- Low-profile nozzle for access into 5/8" diameter holes
- Three different torch body lengths (2", 3-1/2" and 5") for maximum access
- Interchangeable chucks and nozzles for 45°, 90° and 180° applications

**Specifications:**

Amperage: 10 amps to 125 amps  
 Electrode: .040", 1/16" and 3/32"  
 Water flow: 1.0 L/min (.95 qt/min)  
 40 psi minimum  
 1.2 L/min (1.14 qt/min)  
 50 psi maximum

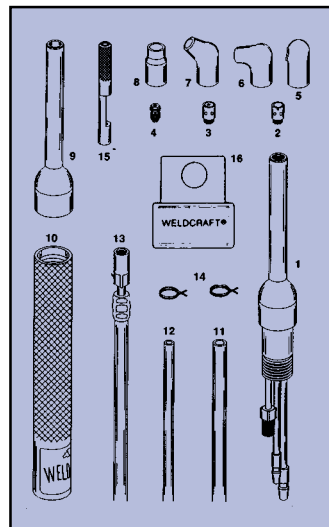

**AK-125: Accessory kit includes:**

- (1) 50C40 chuck
- (1) 125C116 chuck
- (1) 125C40-90 chuck
- (1) 125C116-90 chuck
- (1) 125C40-45 chuck
- (1) 125C116-45 chuck
- (1) 125N90 nozzle
- (1) 125N90S nozzle
- (1) 125N45 nozzle
- (1) 125N180 nozzle
- (1) 53N20 wrench
- (1) .040" tungsten 2% (7")
- (1) 1/16" tungsten 2% (7")

Item No.	Part No.	Description
1	MT-125 MT-125S MT-125L	3-1/2" torch body includes 125S35 2" torch body includes 125S20 5" torch body includes 125S50
2	125C40-90 125C116-90 125C332-90	.040" (1 mm), 90° chuck 1/16" (1.6 mm), 90° chuck 3/32" (2.4 mm), 90° chuck
3	125C40-45 125C116-45 125C332-45	.040" (1 mm), 45° chuck 1/16" (1.6 mm), 45° chuck 3/32" (2.4 mm), 45° chuck
4	50C40 125C116 125N90S	.040" (1 mm), 180° chuck 1/16" (1.6 mm), 180° chuck short 90° glass nozzle (w/screen)
5	125N90SQ	short 90° quartz nozzle
6	125N90 125N90Q	90° glass nozzle 90° quartz nozzle
7	125N45 125N45Q	45° glass nozzle 45° quartz nozzle
8	125N180 125N180Q	180° glass nozzle 180° quartz nozzle
9	125S20 125S35 125S50	2" rubber sleeve 3-1/2" rubber sleeve 5" rubber sleeve
10	53N06	handle
11	45V07 45V08	water hose, 12-1/2' (3.8 m) water hose, 25' (7.6 m)
12	45V09 45V10	gas hose, 12-1/2' (3.8 m) gas hose, 25' (7.6 m)
13	45V03 45V04	power cable, 12-1/2' (3.8 m) power cable, 25' (7.6 m)
14	53N04	hose clamp
15	53N20	chuck wrench
16	45V11	power cable adapter

## Model AHP-10 / Air Cooled Tig Torch / 100 AMPS



Part No.	Description	Amps	Gas Valve	Aircro Equal	Accessory Kit	Hook-Up Kit
AHP-10 AHP-10-12 AHP-10-25	Torch Body Torch Package Torch Package	100	No	2310-1950 2301-0010 2301-0030	2310-1957	HK-3
AHP-10-12V AHP-10-25V	Torch Package Torch Package	100	Slide	2301-0070 2301-0071	2310-1957	HK-2

Torch body only includes nozzle o-ring, nose transfer block  
Torch Packages include: Torch body, handle, power cable assembly.

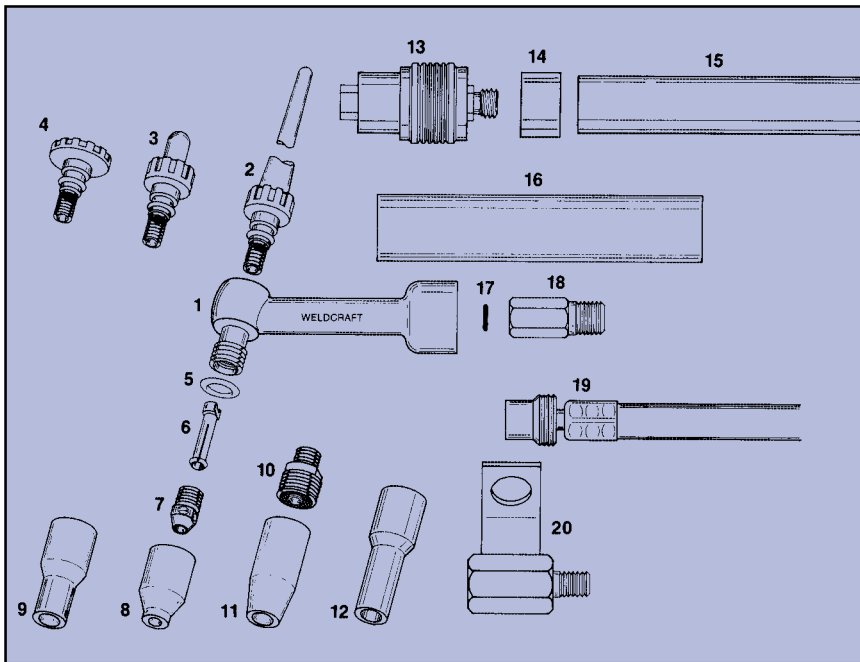

Item No.	Part No.	Description
1	AHP-10	Torch body (2310-1950) includes nozzle O-ring and nose transfer block
2	2304-0010	Long collet cap, includes 2310-0040 O-ring
3	2304-0009	Medium collet cap, includes 2310-0040 O-ring
4	2304-0008	Short collet cap, includes 2310-0040 O-ring
5	2310-0019	Nozzle O-ring
6	-	Collet (See chart A)
7	2310-1810	Nose transfer block
8	-	Short alumina nozzle (See chart B)
9	-	Alumina/lava nozzle—standard style (See chart B)
10	-	Gas flow straightener (See chart A)
11	-	Gas flow straightener nozzle (See chart B)
12	-	Long lava nozzle (See chart B)
13	AV-2	Slide valve
14	-	Spacer
15	-	Handle (valve)
16	2310-1841	Handle
17	830-1306	O-ring
18	2310-0018	Spacer nut
19	-	Hose and cable assembly 2310-1845 12-1/2 ft. (3,8 m) 2310-1844 25 ft. (7,6 m)
20	2310-2101	Power connector (Replaces 2310-1645)
	ZACRK-10	Cable Repair Kit

Not sold separately

Chart A: Collets, Gas Flow Straighteners

Electrode Diameter	.020	.040	1/16	3/32	1/8
Collets	2304-0138	2304-0137	2304-0136	2304-0135	2304-0068
Gas Flow Straighteners	2304-0187		2304-0188		2304-0189

Chart B: Gas Nozzles

SIZE	3	4	5	6	7
Alumina		2304-0069	2304-0070	2304-0073	2304-0074
Short Alumina			2304-0072		
Lava		2304-0002	2304-0004	2304-0049	2304-0050
Long Lava	3L-A	4L-A	5L-A	6L-A	
Gas Flow Str.		2304-0190	2304-0192	2304-0194	2304-0195

Cable Covers: WC-3-10, WC-3-22  
Extension Kit: EK-A10-25  
Master Accessory Kit: MAK-A15

**ACCESSORY KIT: Part No. 2310-1957**

Includes:  
1 Ea. - 2" Collet Cap (2304-0008)  
1 Ea. - 7" Collet Cap (2304-0010)  
1 Ea. - .040 Collet (2304-0137)  
1 Ea. - 1/16 Collet (2304-0136)  
1 Ea. - 3/32 Collet (2304-0135)  
2 Ea. - 1/4 Alumina Nozzle (2304-0069)  
2 Ea. - 5/16 Alumina Nozzle (2304-0070)  
1 Ea. - Nose Transfer Block (2310-1810)

**MASTER ACCESSORY KIT: MAK-A15**

Includes:  
18 Collets: (1) .020", (2) .040", (6) 1/16", (6) 3/32", (3) 1/8"  
6 Nose Transfer Blocks  
7 Collet Caps: (2) Short (3) Medium (2) Long  
8 Nozzle O-Rings  
8 Collet Cap O-Rings  
1 Parts Box  
Parts Box Only: MAK-A1

**EXTENSION KIT - 25 FEET**

**Part No. EK-A10-25**  
Contains couplers and insulator sleeves to extend torch hoses and power cable 25 feet. Maximum capacities must be reduced approximately 25% because of added length of power cable and reduced cooling efficiency.

**HOOK-UP KITS**

**HK-2**  
(For Torch packages using gas valve on torch body)  
1 - Gas Hose, 12-1/2' (40V77)

**HK-3**  
(For Torch packages using gas solenoid valve on machine)  
1 - Gas Hose, 12-1/2' (40V77)  
1 - Gas Hose, 18" (From solenoid valve to power connector)  
Order Correct Power Connector

**Model AHP-16 / Air Cooled Tig Torch / 160 AMPS**



Part No.	Description	Amps	Gas Valve	Airco Equal	Accessory Kit	Hook-Up Kit
AHP-16 AHP-16-12 AHP-16-25	Torch Body Torch Package Torch Package	160	No	2310-1951 & -1941 2301-0047 2301-0049	2310-1958	HK-3
AHP-16-12V AHP-16-25V	Torch Package Torch Package	160	Yes	2301-0084 2301-0085	2310-1958	HK-2

**Torch body** only includes nozzle o-ring, nose transfer block, and 1914A adapter.  
**Torch Packages include:** Torch body, handle, power cable assembly.

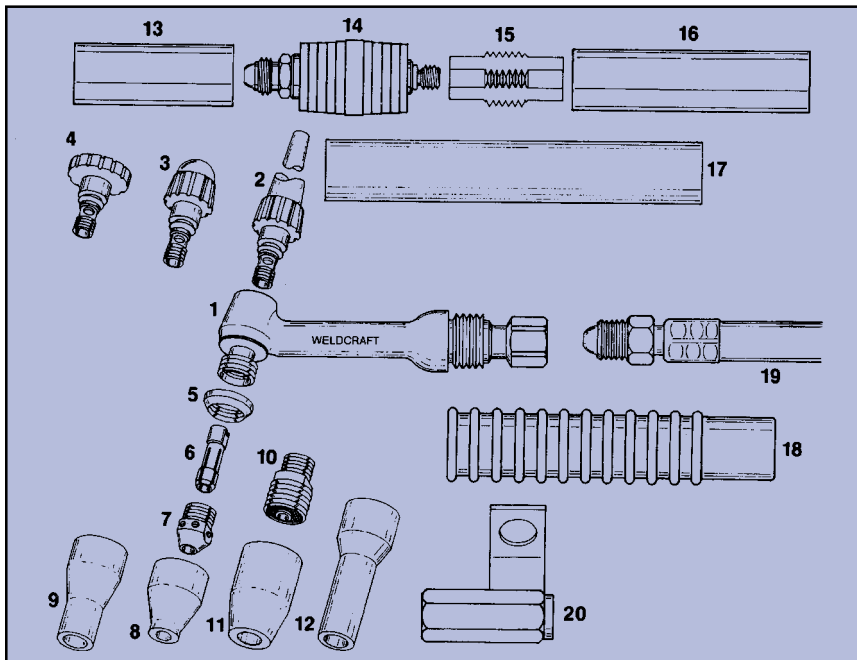

Item No.	Part No.	Description
1	AHP-16	Torch body (2310-1941) includes nozzle gasket, nose transfer block and 1914A adapter
2	2304-0145	Long collet cap, includes 2310-0040 O-ring
3	2304-0144	Medium collet cap, includes 2310-0040 O-ring
4	2304-0143	Short collet cap, includes 2310-0040 O-ring
5	2310-2051	Nozzle gasket
6	-	Collet (See chart A)
7	2310-1938	Nose transfer block
8	-	Short alumina nozzle (See chart B)
9	-	Alumina/lava nozzle - standard style (See chart B)
10	-	Gas flow straightener (See chart A)
11	-	Gas flow straightener nozzle (See chart B)
12	-	Long lava nozzle (See chart B)
13	AV-4	Slide valve
15	-	Front Spacer
16	-	Handle (valve)
17	2310-1862	Handle
18	2310-1862R	Handle
19	-	Hose and cable assembly 2310-1853 12-1/2 ft. (3.8 m) 2310-1854 25 ft. (7.6 m)
20	2310-1879	Power connector
	ZACRK-16	Cable Repair Kit

**Chart A: Collets, Gas Flow Straighteners**

Electrode Diameter	.020	.040	1/16	3/32	1/8	5/32	3/16
Collets	2304-0086	2304-0087	2304-0088	2304-0089	2304-0090	2304-0091	2304-0146
Gas Flow Straighteners	2304-0176			2304-0177	2304-0178	2304-0179	

**Cable Covers:** WC-3-10, WC-3-22  
**Extension Kit:** EK-A16-25  
**Master Accessory Kit:** MAK-A2S

**Chart B: Gas Nozzles**

SIZE	4	5	6	8	10
Alumina	2304-0079	2304-0080	2304-0081	2304-0082	2304-0083
Short Alumina	2304-0084			2304-0085	
Lava	2304-0079C	2304-0080C	2304-0081C	2304-0082C	2304-0083C
Long Lava	4L-79	5L-80	6L-81	8L-82	
Gas Flow Str.	2304-0180	2304-0182	2304-0183	2304-0184	2304-0186

**ACCESSORY KIT Part No. 2310-1958**

Includes:  
1 Ea. - 2" Collet Cap (2304-0143)  
1 Ea. - 7" Collet Cap (2304-0145)  
1 Ea. - 1/16" Collet (2304-0088)  
1 Ea. - 3/32" Collet (2304-0089)  
1 Ea. - 1/8" Collet (2304-0090)  
1 Ea. - 5/32" Collet (2304-0091)  
2 Ea. - 3/8" Alumina Nozzle (2304-0081)  
2 Ea. - 5/8" Alumina Nozzle (2304-0083)  
1 Ea. - Nose Transfer Block (2310-1938)

**MASTER ACCESSORY KIT - MAK-A2S**

20 Collets: (1) .020", (2) .040", (4) 1/16", (5) 3/32", (5) 1/8", (2) 5/32", (1) 3/16"  
5 Nose Transfer Blocks  
5 Collet Caps: (1) Short, (2) Medium, (2) Long  
4 Nozzle Gaskets  
4 Collet Cap O-Rings  
1 Parts Box  
Parts Box Only: MAK-A2

**EXTENSION KIT - 25 FEET**

**Part No. EK-A16-25**  
Contains couplers and insulator sleeves to extend torch hoses and power cable 25 feet. Maximum capacities must be reduced approximately 25% because of added length of power cable and reduced cooling efficiency.

**HOOK-UP KITS**

**HK-2**  
(For Torch packages using gas valve on torch body)  
1 - Gas Hose, 12-1/2' (40V77)

**HK-3**  
(For Torch packages using gas solenoid valve on machine)  
1 - Gas Hose, 12-1/2' (40V77)  
1 - Gas Hose, 18" (From solenoid valve to power connector)  
Order Correct Power Connector

## Model AHP-20 / Water Cooled Tig Torch / 200 AMPS



Part No.	Description	Amps	Aircro Equal	Accessory Kit	Hook-Up Kit
AHP-20	Torch Body	200	2310-1811	2310-1957	HK-A20
AHP-20-12	Torch Package		2301-0041		
AHP-20-25	Torch Package		2301-0042		

Torch body only includes nozzle o-ring, nose transfer block  
Torch Packages include: Torch body, handle, power cable and hoses in protective rubber sheath.

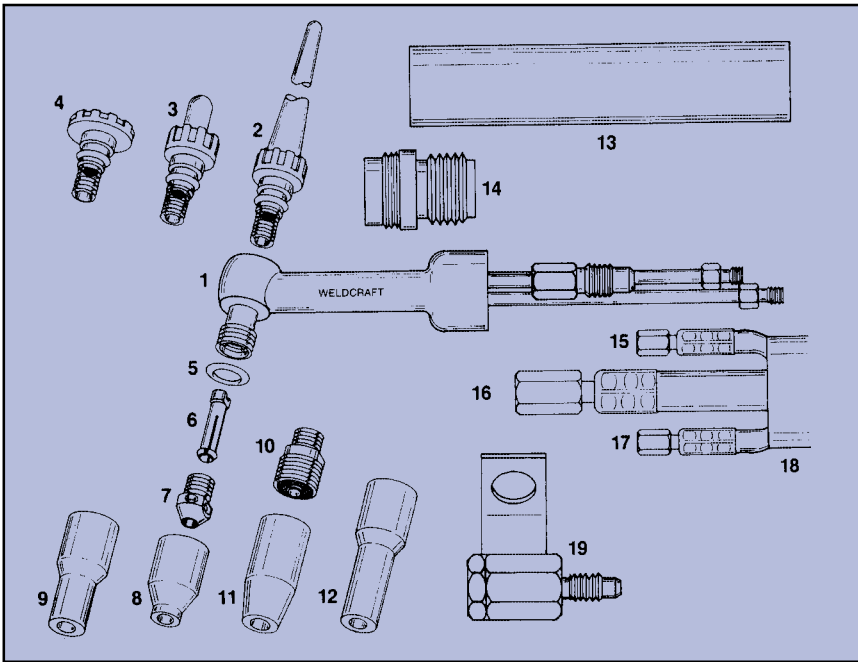

Chart A: Collets, Gas Flow Straighteners

Electrode Diameter	.020	.040	1/16	3/32	1/8
Collets	2304-0138	2304-0137	2304-0136	2304-0135	2304-0068
Gas Flow Straighteners	2304-0187			2304-0188	2304-0189

Chart B: Gas Nozzles

SIZE	3	4	5	6	7
Alumina		2304-0069	2304-0070	2304-0073	2304-0074
Short Alumina			2304-0072		
Lava		2304-0002	2304-0004	2304-0049	2304-0050
Long Lava	3L-A	4L-A	5L-A	6L-A	
Gas Flow Str.		2304-0190	2304-0192	2304-0194	2304-0195

Item No.	Part No.	Description
1	AHP-20	Torch body (2310-1811) includes nozzle O-ring and nose transfer block
	2304-0010	Long collet cap, includes 2310-0040 O-ring
	2304-0009	Medium collet cap, includes 2310-0040 O-ring
	2304-0008	Short collet cap, includes 2310-0040 O-ring
5	2310-0019	Nozzle O-ring
6	-	Collet (See chart A)
7	2310-1810	Nose transfer block
8	-	Short alumina nozzle (See chart B)
9	-	Alumina/lava nozzle - standard style (See chart B)
10	-	Gas flow straightener (See chart A)
11	-	Gas flow straightener nozzle (See chart B)
12	-	Long lava nozzle (See chart B)
13	2310-1815	Handle
14	2310-1833	Coupling
15	-	Gas hose assembly 2310-1806 12-1/2 ft. (3.8 m) 2310-1805 25 ft. (7.6 m)
16	-	Hose and cable assembly 2310-1817 12-1/2 ft. (3.8 m) 2310-1818 25 ft. (7.6 m)
17	-	Water hose assembly 2310-1808 12-1/2 ft. (3.8 m) 2310-1807 25 ft. (7.6 m)
18	-	Hose and cable package in sheath 2310-1935 12-1/2 ft. (3.8 m) 2310-1936 25 ft. (7.6 m)
19	-	2310-1824 Power connector
		<b>Cable Repair Kits</b>
	ZACRK-20	Power Cable Repair Kit
	ZAGHK-20	Gas Hose Repair Kit
	ZAWHK-20	Water Hose Repair Kit

**Cable Covers:** WC-3-10, WC-3-22  
**Extension Kit:** EK-A20-25  
**Master Accessory Kit:** MAK-A1S

**ACCESSORY KIT: Part No. 2310-1957**

Includes:  
1 Ea. - 2" Collet Cap (2304-0008)  
1 Ea. - 7" Collet Cap (2304-0010)  
1 Ea. - .040" Collet (2304-0137)  
1 Ea. - 1/16" Collet (2304-0136)  
1 Ea. - 3/32" Collet (2304-0135)  
2 Ea. - 1/4" Alumina Nozzle (2304-0069)  
2 Ea. - 5/16" Alumina Nozzle (2304-0070)  
1 Ea. - Nose Transfer Block (2310-1810)

**EXTENSION KIT - 25 FEET**

**Part No. EK-A20-25**  
Contains couplers and insulator sleeves to extend torch hoses and power cable 25 feet. Maximum capacities must be reduced approximately 25% because of added length of power cable and reduced cooling efficiency.

**MASTER ACCESSORY KIT: MAK-A1S**

Includes:  
18 Collets: (1) .020", (2) .040", (6) 1/16", (6) 3/32", (3) 1/8"  
6 Nose Transfer Blocks  
7 Collet Caps: (2) Short (3) Medium (2) Long  
8 Nozzle O-Rings  
8 Collet Cap O-Rings  
1 Parts Box  
Parts Box Only: MAK-A1

**HOOK-UP KIT: HK-A20**

1 - Power Connector (2310-1824)  
2 - Water Hoses, 12-1/2" (40V76)  
1 - Water Hose Coupler (11N18)  
2 - Water Adapter Fitting (1/4" NPT - Hose)  
1 - Gas Hose, 12-1/2" (40V77)

**Model AHP-35 / Water Cooled Tig Torch / 350 AMPS**



Part No.	Description	Amps	Airco Equal	Accessory Kit	Hook-Up Kit
AHP-35	Torch Body	350	2310-1952	2310-1958	HK-A35
AHP-35-12	Torch Package		2301-3751		
AHP-35-25	Torch Package		2301-3776		

**Torch body** only includes nozzle gasket, nose transfer block  
**Torch Packages include:** Torch body, handle, power cable and hoses in protective rubber sheath.

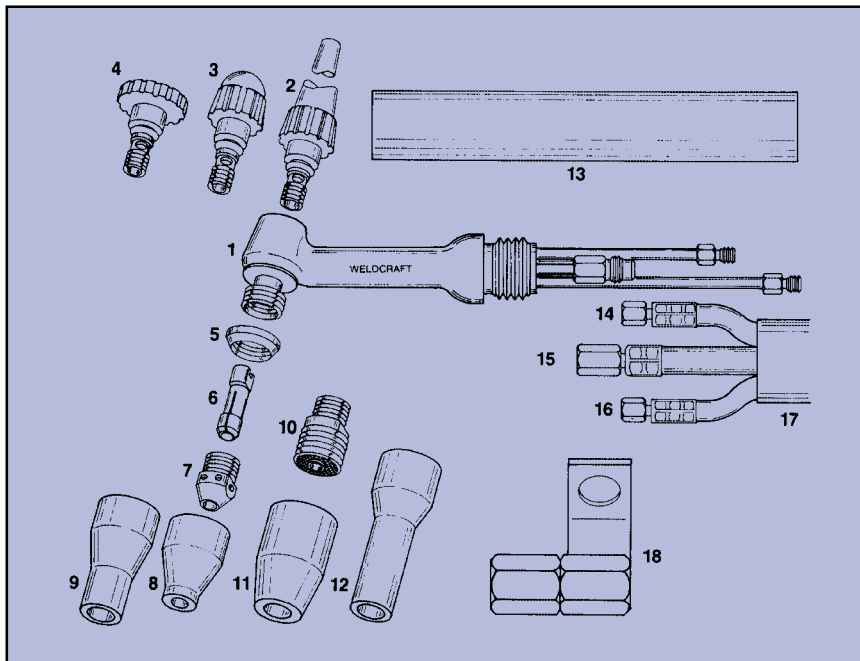

Item No.	Part No.	Description
1	AHP-35	Torch body (2310-1952) includes nozzle gasket and nose transfer block
2	2304-0145	Long collet cap, includes 2310-0040 O-ring
3	2304-0144	Medium collet cap, includes 2310-0040 O-ring
4	2304-0143	Short collet cap, includes 2310-0040 O-ring
5	2310-2051	Nozzle gasket
6	-	Collet (See chart A)
7	2310-1938	Nose transfer block
8	-	Short alumina nozzle (See chart B)
9	-	Alumina/lava nozzle - standard style (See chart B)
10	-	Gas flow straightener (See chart A)
11	-	Gas flow straightener nozzle (See chart B)
12	-	Long lava nozzle (See chart B)
13	2310-1862	Handle
14	-	Gas hose assembly 2310-1873 12-1/2 ft. (3.8 m) 2310-1869 25 ft. (7.6 m)
15	-	Hose and cable assembly 2310-1856 12-1/2 ft. (3.8 m) 2310-1857 25 ft. (7.6 m)
16	-	Water hose assembly 2310-1871 12-1/2 ft. (3.8 m) 2310-1870 25 ft. (7.6 m)
17	-	Hose and cable package in sheath 2310-1953 12-1/2 ft. (3.8 m) 2310-1954 25 ft. (7.6 m)
18	2310-0735	Power connector
		<b>Cable Repair Kits</b>
	ZACRK-35	Power Cable Repair Kit
	ZAGHK-35	Gas Hose Repair Kit
	ZAWHK-35	Water Hose Repair Kit

**Chart A: Collets, Gas Flow Straighteners**

Electrode Diameter	.020	.040	1/16	3/32	1/8	5/32	3/16
Collets	2304-0086	2304-0087	2304-0088	2304-0089	2304-0090	2304-0091	2304-0146
Gas Flow Straighteners	2304-0176		2304-0177	2304-0178	2304-0179		

**Chart B: Gas Nozzles**

SIZE	4	5	6	8	10
Alumina	2304-0079	2304-0080	2304-0081	2304-0082	2304-0083
Short Alumina	2304-0084			2304-0085	
Lava	2304-0079C	2304-0080C	2304-0081C	2304-0082C	2304-0083C
Long Lava	4L-79	5L-80	6L-81	8L-82	
Gas Flow Str.	2304-0180	2304-0182	2304-0183	2304-0184	2304-0186

**Cable Covers:** WC-3-10, WC-3-22  
**Extension Kit:** EK-A35-25  
**Master Accessory Kit:** MAK-A2S

**ACCESSORY KIT Part No. 2310-1958**

Includes:  
1 Ea. - 2" Collet Cap (2304-0143)  
1 Ea. - 7" Collet Cap (2304-0145)  
1 Ea. - 1/16" Collet (2304-0088)  
1 Ea. - 3/32" Collet (2304-0089)  
1 Ea. - 1/8" Collet (2304-0090)  
1 Ea. - 5/32" Collet (2304-0091)  
2 Ea. - 3/8" Alumina Nozzle (2304-0081)  
2 Ea. - 5/8" Alumina Nozzle (2304-0083)  
1 Ea. - Nose Transfer Block (2310-1938)

**EXTENSION KIT - 25 FEET**

**Part No. EK-A35-25**  
Contains couplers and insulator sleeves to extend torch hoses and power cable 25 feet. Maximum capacities must be reduced approximately 25% because of added length of power cable and reduced cooling efficiency.

**MASTER ACCESSORY KIT Part No. MAK-A2S**



20 Collets: (1) .020", (2) .040", (4) 1/16", (5) 3/32", (5) 1/8", (2) 5/32", (1) 3/16"  
5 Nose Transfer Blocks  
5 Collet Caps: (1) Short, (2) Medium, (2) Long  
4 Nozzle Gaskets  
4 Collet Cap O-Rings  
1 Parts Box  
Parts Box Only: MAK-A2

**HOOK-UP KIT Part No. HK-A35**

1 - Power Connector (2310-0735)  
2 - Water Hoses, 12-1/2' (40V76)  
1 - Water Hose Coupler (11 N18)  
2 - Water Adapter Fitting (1/4" NPT - Hose)  
1 - Gas Hose, 12-1/2' (40V77)

**Flex Torches**

**SF-225 Water-Cooled Flexible Torch Body & WP-25 Long Reach Flex-Pencil Type Water-Cooled Torch Body**

Torch Body	Part No.	Description	Max Amps	Cooling	Power Cable	Water Hose	Gas Hose	Handle
 Each SF-225 torch package includes: Torch body, 9-70 and 1726 heads, power cable assy and handle.	SF-225	Torch Body	225	Water	45V03	45V07	45V09	53N06
	SF-225-12	Torch Package						
	SF-225-25	Torch Package						
	SF-225-12-HD	Torch Package						
	SF-225-25-HD	Torch Package						
	SF-225-12-R	Torch Package						
SF-225-25-R	Torch Package							
 WP-25 torch packages include: Torch body, handle and power cable assy.	WP-25	Torch Body	200	Water	45V03	45V07	45V09	53N06
	WP-25-12	Torch Package						
	WP-25-25	Torch Package						
	WP-25-12-HD	Torch Package						
	WP-25-25-HD	Torch Package						
	WP-25-12-R	Torch Package						
WP-25-25-R	Torch Package							



**WP-150/200 Air Cooled Flexible Torch Body Assembly**

Part No.	Max Amps	Cooling	Gas Valve	Torch Body	Element
WP-150	80-150	AIR	NO	150TB	150CE
WP-150V	80-150	AIR	YES	150VTB	150CE
WP-200	150-200	AIR	NO	200TB	200CE
WP-200V	150-200	AIR	YES	200VTB	200CE

Each WP-150/150V and WP-200/200V Torch package includes:  
 9-70 and 1726 heads, heavy duty 2 pc. power cable, coil element, solid element, handle and wrench.

**Torch Package Assembly**

Part No.	Max Amps	Cooling	Gas Valve	Torch Body	Coil Element	Handle
WP-150-12-2	150	AIR	NO	150TB	150CE	105Z55R
WP-150V-12-2			YES	150VTB		
WP-150-25-2			NO	150TB		
WP-150V-25-2			YES	150VTB		
WP-200-12-2	200	AIR	NO	200TB	200CE	10N15R
WP-200V-12-2			YES	200VTB		
WP-200-25-2			NO	200TB		
WP-200V-25-2			YES	200VTB		

**Interchangeable Heads**



Parts Used	Part No.	Maximum Amps		Head Angle
		A/C	W/C	
WP-9, 9P, 9V WP-20, 20P, 25	9-70	125	200	70°
	9-90	125	200	90°
	09-P	125	200	180°
WP-24, 24W	0024	80	160	70°
	24-90	80	160	90°
WP-17,17V WP-18,18V WP-26,26V	1726	150/200	225	70°
	1726P	150/200	225	180°

**Flex-Neck Parts**

Part No.	Description	Torch
150TB	Torch Body	9F, 17F, 24F WP150
150VTB	Torch Body (valve)	9F, 17F, 24F WP150V
300LN	Lock Nut	9F, 17F, 24F WP150
150W	Wrench	9F, 17F, 24F, WP150
105Z55R	Handle	9F, 17F, 24F, WP150
10N15R	Handle	16F, 26F, WP200, 200V
200W	Wrench	16F, 26F, WP200, 200V
200LN	Lock Nut	16F, 26F, WP200, 200V
200TB	Torch Body	16F, 26F, WP200
200VTB	Torch Body (valve)	16F, 26F, WP200V
150CE	Coil Element	WP150, 150V
200CE	Coil Element	WP200, 200V
150SE	Solid Element (converts torch to rigid neck)	WP150, 150V
200SE	Solid Element (converts torch to rigid neck)	WP200, 200V
150TB-AA	Rubber Torch Body	9F, 17F, 24F, WP150
200TB-AA	Rubber Torch Body	16F, 26F, WP200



**Air-Cooled Flex**

Part No.	Max Amps	Accessory Parts Used
009F	125	WP-9, 9P, 9V, 20, 20P, 25
017F	150	WP-17, 17V
026F	200	WP-18, 18V, 26, 26V
024F	80	WP-24
016F	160	AHP-16, 35

**Torch Body Assembly**

Torch Assembly	Max. Amp	Cooling	Gas Valve	Torch Body
WP-9F	125	AIR	NO	150TB
WP-9FV	125	AIR	YES	150VTB
WP-17F	150	AIR	NO	150TB
WP-17FV	150	AIR	YES	150VTB
WP-26F	200	AIR	NO	200TB
WP-26FV	200	AIR	YES	200VTB
WP-24F	80	AIR	NO	150TB
WP-24FV	80	AIR	YES	150VTB
WP-16F	160	AIR	NO	200TB
WP-16FV	160	AIR	YES	200VTB

**Torch Package Assembly**

Torch Assembly	Head Style	Max Amps	Cooling	Ribbed Handle
WP-9F-12-2 WP-9F-25-2 WP-9FV-12-2 (valve) WP-9FV-25-2 (valve)	9F	125	AIR	105Z55R
WP-17F-12-2 WP-17F-25-2 WP-17FV-12-2 (valve) WP-17FV-25-2 (valve)	17F	150	AIR	105Z55R
WP-26F-12-2 WP-26F-25-2 WP-26FV-12-2 (valve) WP-26FV-25-2 (valve)	26F	200	AIR	10N15R
WP-24F-12-2 WP-24F-25-2 WP-24FV-12-2 (valve) WP-24FV-25-2 (valve)	24F	80	AIR	105Z55R
WP-16F-12-2 WP-16F-25-2 WP-16FV-12-2 (valve) WP-16FV-25-2 (valve)	16F	160	AIR	10N15R

(includes: Torch body assembly, ribbed handle, 2-piece power cable, wrench)

**Starter Kits**



Includes: Torch package, accessory kit (except Crafter Series), hook-up kit, power cable adapter (when necessary), 25' ground cable and clamp assembly (1/0 cable).



Part No.	Torch Package	Accessory Kit	Hook-Up Kit	Power Cable Adapter
<b>AIR COOLED</b>				
SWP-17-25-R	WP-17-25-R	AK-2	HK-3	105Z57
SQWP-17-25-R	QWP-17-25-R	AK-2	QHK-2	QCS-M
SWP-17-25-2	WP-17-25-2	AK-2	HK-3	N/A
SQWP-17-25-2	QWP-17-25-2	AK-2	QHK-2	QCS-M
SWP-17V-25-R	WP-17V-25-R	AK-2	HK-2	105Z57
SQWP-17V-25-R	QWP-17V-25-R	AK-2	QHK-2	QCS-M
SWP-17V-25-2	WP-17V-25-2	AK-2	HK-2	N/A
SQWP-17V-25-2	QWP-17V-25-2	AK-2	QHK-2	QCS-M
SWP-26-25-R	WP-26-25-R	AK-3	HK-3	45V62
SQWP-26-25-R	QWP-26-25-R	AK-3	QHK-2	QCS-M
SWP-26-25-2	WP-26-25-2	AK-3	HK-3	N/A
SQWP-26-25-2	QWP-26-25-2	AK-3	QHK-2	QCS-M
SWP-26V-25-R	WP-26V-25-R	AK-3	HK-2	45V62
SQWP-26V-25-R	QWP-26V-25-R	AK-3	QHK-2	QCS-M
SWP-26V-25-2	WP-26V-25-2	AK-3	HK-2	N/A
SQWP-26V-25-2	QWP-26V-25-2	AK-3	QHK-2	QCS-M
<b>WATER COOLED</b>				
SWP-18-25	WP-18-25	AK-3	HK-1	in HK-1
SQWP-18-25	QWP-18-25	AK-3	QHK-1	QCS-M
SWP-20-25	WP-20-25	AK-4	HK-1	in HK-1
SQWP-20-25	QWP-20-25	AK-4	QHK-1	QCS-M
SSF-225-25-R	*SF-225-25-R	AK-8	HK-1	in HK-1
SQSF-225-25-R	*QSF-225-25-R	AK-8	QHK-1	QCS-M
*Includes 9-70 and 1726 heads				
<b>CRAFTER SERIES</b>				
SCS310-25	CS310-25	Weld to ready	HK-1	in HK-1
SQCS310-25	QCS310-25	*See below	QHK-1	QCS-M
SCS410-25	CS410-25	Weld to ready	HK-1	in HK-1
SQCS410-25	QCS410-25	**See below	QHK-1	QCS-M

\* CS310 Torches include: 13N23, 13N28, 13N10HPN (3/32" collet, collet body, HPN nozzle and cable cover.)

\*\*CS410 Torches include: 10N25, 10N28, 10N46HPN (1/8" collet, collet body, HPN nozzle and cable cover.)



Part No. HK-3

**HOOK-UP KITS**

**WATER- COOLED TORCHES**

- HK-1**
- 1- Power Cable Adapter (45V11)
  - 2- Water Hose, 12-1/2' (40V76)
  - 1- Water Hose Coupler (11N18)
  - 2- WaterAdapter Fittings, 1/4" NPT Male to hose.
  - 1- Gas Hose, 12-1/2' (40V77)

**AIR COOLED TORCHES**

- HK-2 (for torches with built-in gas valve)**
- 1- Gas Hose, 12-1/2' with IAA fittings
- HK-3 (for torches using gas solenoid valve on machine)**
- 1- Gas Hose, 12-1/2' (40V77)
  - 1- Gas Hose, 18" (from Solenoid Valve to Power Cable Connector)

- QHK-1**
- 2- Water Hoses, 12-1/2' (40V76)
  - 1- Water Hose Coupler (11N18)
  - 2- Quick release water adapters (QRW)
  - 1- Gas Hose 12-1/2' (40V77)
  - 1- Gas Hose Coupler (11N17)
  - 1- Quick release gas adapter (QRG)

- QHK-2**
- 1- Gas Hose 12-1/2' (40V77)
  - 1- Gas Hose Coupler (11 N17)
  - 1- Quick release gas adapter (QRG)

**ACCESSORY KITS**

- AK-2 (WP-17, 17V)**
- 1- Short Back Cap
  - 3- Collets .040", 1/16", 3/32"
  - 3- Collet Bodies .040", 1/16", 3/32"
  - 3- Al. Nozzles 4,5,6
  - 3- Tungsten Electrodes 2% .040", 1/16", 3/32" X 7"

- AK-3 (WP-18, 18V, 26, 26V)**
- 1- Short Back Cap
  - 3- Collets 1/16", 3/32", 1/8"
  - 3- Collet Bodies 1/16", 3/32", 1/8"
  - 3- Al. Nozzles 5,6,8
  - 3- Tungsten Electrodes 2% 1/16", 3/32", 1/8" X 7"

- AK-4 (WP-20)**
- 1- Short Back Cap
  - 3- Collets 1/16", 3/32", 1/8"
  - 3- Collet Bodies 1/16", 3/32", 1/8"
  - 3- Al. Nozzles 5,6,7
  - 3- Tungsten Electrodes 2% 1/16", 3/32", 1/8", X 7"

- AK-8 (SF-225)**
- 1-10N24 3/32 Collet
  - 1-10N32 3/32 Collet Body
  - 1-10N46HPN #8 HPN Nozzle
  - 1- 57Y02 Back Cap
  - 1-13N23 3/32 Collet
  - 1- 45V44 3/32 Gas Lens
  - 1- 53N61 HPN #7 HPN Nozzle
  - 1- 41V35 Medium Back Cap
  - 1- Tungsten Electrode 2% 3/32" X 7"

**CRAFTER SERIES™**

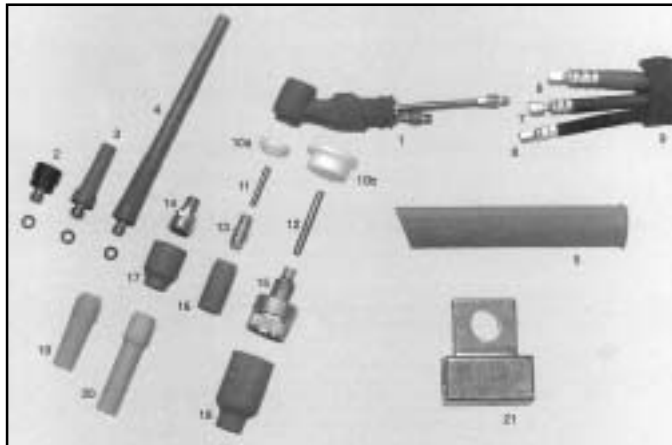

**Crafter Series Ordering Guide - 310 AMP**

- CS310-12 w/ 12' cable
- CS310-12HK w/ 12' cable and hookup kit
- CS310-25 w/ 25' cable
- CS310-25HK w/ 25' cable and hookup kit
- QCS310-\_\_\_ Q prefix adds a complete kit of Weldcraft's QCS quick connect cable fittings

**CS310 torch packages come assembled with:** Torch body, handle, gas & water hoses, power cable, cable cover, #6 HPN nozzle, 3/32" collet, 3/32" collet body, 3/32" x 7" tungsten electrode and long back cap.

- CS310-UAK Universal Accessory Kit, contains:**
- (1) each 3/32" and 1/8" collets
  - (1) each 3/32" and 1/8" collet bodies
  - (1) each 3/32" and 1/8" gas lens collet bodies
  - (1) each 3/32" x 7" and 1/8" x 7" tungsten electrodes
  - (1) each Short, medium and long back caps
  - (1) each #5 and #6 alumina nozzles
  - (1) each #5 and #6 gas lens alumina nozzles

- CS310-PCRK Power Cable Repair Kit
- CS310-GHRK Gas Hose Repair Kit
- CS310-WHRK Water Hose Repair Kit
- HK-1 Hookup kit

Item No.	Part No.	Description
1	CS310A	Torch body, includes 598882 insulator
2	CS110-BCS	Back cap, short, includes 98W77 O-ring
3	CS110-BCM	Back cap, medium, includes 98W77 O-ring
4	CS110-BCL	Back cap, long, includes 98W77 O-ring
5	CS110-H	D-Handle
6	CS310-12PC	Power cable, red, 12.5' (3.8 m)
	CS310-25PC	Power cable, red, 25' (7.6 m)
	QCS310-12PC	Quick connect power cable, red, 12.5' (3.8 m)
	QCS310-25PC	Quick connect power cable, red, 25' (7.6 m)
7	CS310-12W	Water hose, blue, for CS310 and CS410, 12.5' (3.8 m)
	CS310-25W	Water hose, blue, for CS310 and CS410, 25' (7.6 m)
8	CS310-12G	Gas hose, black, 12.5' (3.8 m)
	CS310-25G	Gas hose, black, 25' (7.6 m)
9	CS-3-10CC	Cable cover, 10' (3.0 m)
	CS-3-22CC	Cable cover, 22' (6.7m)
10a	598882	Teflon insulator
10b	54N63-20	Teflon insulator, for large diameter gas lenses
21	45V11	Power cable adapter



**Chart A: Collets, Collet Bodies, Gas Lens**

Item No.	Electrode Diameter	.020	.040	1/16	3/32	1/8
11	Collet	13N20	13N21	13N22	13N23	13N24
12	Lg. Gas Lens Collet	13N20L	13N21L	13N22L	13N23L	13N24L
13	Collet Body	13N25	13N26	13N27	13N28	13N29
14	Gas Lens	45V41	45V42	45V43	45V44	45V45
15	Lg. Gas Lens Collet Body	45V0204S		45V116S	45V64S	995795S

**Chart B: Gas Nozzles - HPN: High Performance Nozzles Available**

Item No.	SIZE	4	5	6	7	8	10	12
16	Alumina	13N08	13N09	13N10 •	13N11 •	13N12	13N13	
17	Gas Lens Alumina	53N58 •	53N59 •	53N60 •	53N61 •	53N61S •		
18	Lg. Gas Lens Alumina					57N74	53N88 •	53N87 •
19	Long Lava Nozzle**	796F71	796F72	796F73				
20	X-tra Lg. Lava Nozzle	796F75	796F76	796F77				

\*\* Also available in Alumina. Ex. A796F71

• HPN Nozzle available.

**Crafter Series 410 AMP**

**CRAFTER SERIES™**

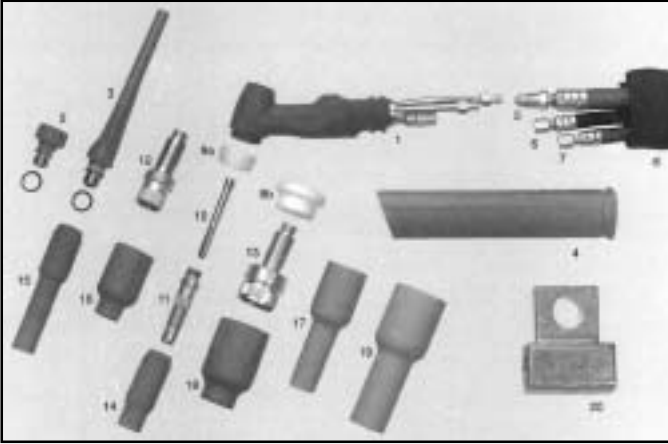

**Crafter Series Ordering Guide - 410 AMP**

- CS410-12 w/ 12' cable
- CS410-12HK w/ 12' cable and hookup kit
- CS410-25 w/ 25' cable
- CS410-25HK w/ 25' cable and hookup kit
- QCS410-\_\_\_ Q prefix adds a complete kit of Weldcraft's QCS quick connect cable fittings

**CS410 torch packages come assembled with:** Torch body, handle, gas & water hoses, power cable, cable cover, #8 HPN nozzle, 1/8" collet, 1/8" collet body, 1/8" x 7" tungsten electrode and long back cap.

- CS410-UAK Universal Accessory Kit, contains:**
- (1) each 1/8" and 5/32" collets
  - (1) each 1/8" and 5/32" collet bodies
  - (1) each 1/8" and 5/32" gas lens collet bodies
  - (1) each 1/8" x 7" and 5/32" x 7" tungsten electrodes
  - (1) each Short, and long back caps
  - (1) each #7 and #8 alumina nozzles
  - (1) each Gas lens insulator
  - (2) each #7 and #8 gas lens alumina nozzles

- CS410-PCRK Power Cable Repair Kit
- CS410-GHRK Gas Hose Repair Kit
- CS310-WHRK Water Hose Repair Kit
- HK-1 Hookup kit

Item No.	Part No.	Description
1	CS410A	Torch body, includes 18CG
2	CS210-BCS	Back cap, short, includes 98W18 O-RING
3	CS410-BCL	Back cap, Long, includes 98W18 O-RING
—	CS210-H	Handle
5	CS410-12PC	Power Cable, Red, 12.5' (3.8 M)
	CS410-25PC	Power Cable, Red, 25' (7.6 M)
	QCS410-12PC	Quick Connect Power Cable, Red, 12.5' (3.8 M)
	QCS410-25PC	Quick Connect Power Cable, Red, 25' (7.6 M)
6	CS310-12W	Water Hose, Blue, for CS310 and CS410, 12.5' (3.8 M)
	CS310-25W	Water Hose, Blue, for CS310 and CS410, 25' (7.6 M)
7	CS410-12G	Gas Hose, Black, 12.5' (3.8 M)
	CS410-25G	Gas Hose, Black, 25' (7.6 M)
8	CS-4-10CC	Cable Cover, 10' (3.0 M)
	CS-4-22CC	Cable Cover, 22' (6.7 M)
9a	18CG	Cup Gasket
	54N01	Gas lens insulator
9b	54N63	Large diameter gas lens insulator
20	45V11	Power cable adapter



**Chart A: Collets, Collet Bodies, Gas Lens**

Item No.	Electrode Diameter	.020	.040	1/16	3/32	1/8	5/32
10	Collet	10N21	10N22	10N23	10N24	10N25	54N20
11	Collet Body	10N29	10N30	10N31	10N32	10N28	406488
12	Gas Lens	45V29	45V24	45V25	45V26	45V27	45V28
13	Lg. Dia. Gas Lens	45V0204		45V116	45V64	995795	45V63

**Chart B: Gas Nozzles - HPN: High Performance Nozzles Available**

Item No.	SIZE	4	5	6	7	8	10	12
14	Alumina	10N50	10N49	10N48 •	10N47 •	10N46 •	10N45	10N44
15	Lg Alumina Nozzle		10N49L	10N48L	10N47L			
16	Gas Lens Alumina	54N18	54N17	54N16	54N15 •	54N14 •		
17	Long Gas Lens Alumina		54N17L	54N16L	54N15L			
18	Lg. Dia. Gas Lens Alumina			57N75		57N74	53N88 •	53N87 •
19	Lg. Lrg. Dia. Gas Lens Alumina			57N75L		57N74L	53N88L	53N87L

• HPN Nozzle available.