



Large Oxygen & #5 or WK Acetylene Cylinder Trucks

Anthony's new "User Friendly" ergonomic handle design (patent pending) helps provide a more comfortable positioning of the hands for better control and maneuverability of the cart.



High Rail Design

These models are designed for (1) large oxygen and (1) #5 or WK acetylene cylinder side-by-side. Features include our new "User Friendly" heavy gauge wrap around handle, high side rail design providing more positive cylinder containment, large tool tray and our exclusive fast action cylinder placement band with large tightening knob.



Part No. 24-14
WHEEL TYPE:
14" x 1.75" SOLID RUBBER



Part No. 24-24
WHEEL TYPE:
24" x 2.00" STEEL



Part No. 24-16
WHEEL TYPE:
16" x 4.00" PNEUMATIC

Low Rail Design

For the user who prefers the look and construction of a low rail cylinder truck, these models are designed for (1) large oxygen and (1) #5, WK, or 100 lb. propane cylinder side-by-side. Features include our new "User Friendly" heavy gauge wrap around handle, large tool tray and zinc plated safety chain.



Part No. 2-14
WHEEL TYPE:
14" x 1.75" SOLID RUBBER



Part No. 2-24
WHEEL TYPE:
24" x 2.00" STEEL



Part No. 2-16
WHEEL TYPE:
16" x 4.00" PNEUMATIC

Solid bar threaded axles and lock nuts are standard on all models.

Part No.	Wheel Diameter & Type	Maximum Diameter Oxygen Cylinder	Maximum Diameter Acetylene Cylinder	Combined Cylinder Diameter	Height	Width (O.D.)	Weight * shippable via ups
24-14	14" x 1.75" Solid Rubber	9 1/2"	13 1/2"	23"	47"	29"	53
24-24	24" x 2.00" Steel	9 1/2"	13 1/2"	23"	47"	32"	64
24-16	16" x 4.00" Pneumatic	9 1/2"	13 1/2"	23"	47"	33"	57
24-24RT	24" x 6.00" Pneumatic	9 1/2"	13 1/2"	23"	47"	37"	77
2-14	14" x 1.75" Solid Rubber	9 1/2"	15"	24 1/2"	47"	36"	86
2-24	24" x 2.00" Steel	9 1/2"	15"	24 1/2"	47"	34"	63
2-16	16" x 4.00" Pneumatic	9 1/2"	15"	24 1/2"	47"	36"	56
2-24RT	24" x 6.00" Pneumatic	9 1/2"	15"	24 1/2"	47"	40"	76



Small and Medium Size Cylinder Trucks

Small Size Cylinder Trucks

These very popular models are designed to handle a 50 to 80 cubic ft. oxygen and 40 cubic ft. acetylene or (1 cylinder up to 8" in dia.) and (1 cylinder up to 7" in dia.) These trucks are ideal for use in repair shops, garages or where casual welding requirements may apply. Features include a reinforced frame, welding rod holders, zinc plated safety chain and large 7" solid rubber wheels.



Part No. 0038
WHEEL TYPE:
7" x 1.50" SOLID RUBBER

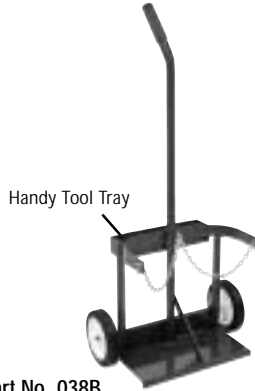

Part No. 038B
EQUIPPED WITH A
HANDY TOOL TRAY

Medium Size Cylinder Trucks

These very popular models are designed to handle an 80 to 150 cubic ft. oxygen and small or medium acetylene or (1 cyl. up to 8-1/2" in dia.) and (1 cyl. up to 8" in dia.) These trucks are ideal for use in repair shops, garages, or where casual welding requirements may apply. Features include a reinforced frame, handy tool tray, welding rod holders and zinc plated safety chain.



Part No. 0039
WHEEL TYPE:
7" x 1.50" SOLID RUBBER

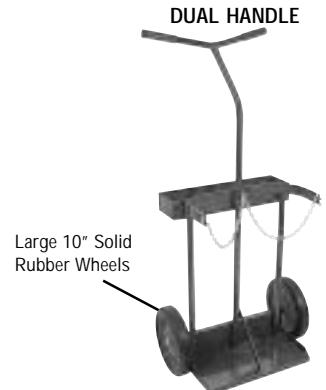

Part No. 039V
WHEEL TYPE:
10" x 1.75" SOLID RUBBER

Medium Size Cylinder Trucks (Combined Cyl. Dia. - 16-1/2")

Anthony's new "User Friendly" ergonomic handle design (patent pending) helps provide a more comfortable positioning of the hands for better control and maneuverability of the cart.



High Rail Frame Design



Part No. 41-10
WHEEL TYPE:
10" x 1.75" SOLID RUBBER



Part No. 41-16
WHEEL TYPE:
16" x 4.00" PNEU.



Part No. 41-14
WHEEL TYPE:
14" x 1.75" SOLID RUBBER

Low Rail Frame Design



Part No. 4-14
WHEEL TYPE:
14" x 1.75" SOLID RUBBER



Part No. 4-16
WHEEL TYPE:
16" x 4.00" PNEU.



Part No. 4-10
WHEEL TYPE:
10" x 1.75" SOLID RUBBER

Part No.	Wheel Dia. & Type	Max. Dia. Oxy. Cyl.	Max. Dia. Acet. Cyl.	Combined Cyl. Dia.	Height	Width	Weight *shippable via UPS
0038	7" x 1.50" S/R	7"	8"	15"	41"	19"	17 *
038B	7" x 1.50" S/R	7"	8"	15"	41"	19"	19 *
0039	7" x 1.50" S/R	8"	8 1/2"	16 1/2"	44"	21"	22 *
039V	10" x 1.75" S/R	8"	8 1/2"	16 1/2"	44"	21"	28 *
41-10	10" x 1.75" S/R	8 1/4"	8 1/4"	16 1/2"	42"	22"	34 *
41-14	14" x 1.75" S/R	8 1/4"	8 1/4"	16 1/2"	42"	22"	44 *
41-16	16" x 4.00" Pneu.	8 1/4"	8 1/4"	16 1/2"	42"	27"	49 *
41-14S	14" x 2.00" Steel	8 1/4"	8 1/4"	16 1/2"	42"	26"	35 *
4-14S	14" x 2.00" Steel	9 1/4"	9 1/4"	18 1/2"	42"	26"	35 *
4-14	14" x 1.75" S/R	9 1/4"	9 1/4"	18 1/2"	42"	26"	44 *
4-16	16" x 4.00" Pneu.	9 1/4"	9 1/4"	18 1/2"	42"	31"	49 *
4-10	10" x 1.75" S/R	9 1/4"	9 1/4"	18 1/2"	42"	26"	34 *



Large Oxygen & Medium Acetylene Cylinder Trucks

Anthony's new "User Friendly" ergonomic handle design (patent pending) helps provide a more comfortable positioning of the hands for better control and maneuverability of the cart.



High Rail Design

These models are designed for (2) high or low pressure cylinders side-by-side. Features include our new "User Friendly" heavy gauge wrap around handle, high side rail design providing more positive cylinder containment, large tool tray and our exclusive fast action cylinder placement band with large tightening knob.



Part No. 85-14
WHEEL TYPE:
14" x 1.75" SOLID RUBBER



Part No. 85-10
WHEEL TYPE:
10" x 1.75" SOLID RUBBER

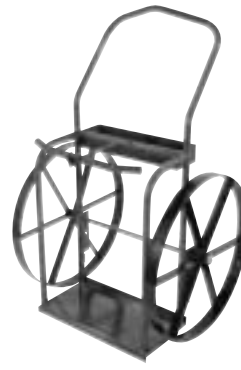

Part No. 85-24
WHEEL TYPE:
24" x 2.00" STEEL



Part No. 85-16
WHEEL TYPE:
16" x 4.00" PNEUMATIC

Low Rail Design

For the user who prefers the look and construction of a low rail cylinder truck, these models are designed for (2) high or low pressure cylinders side-by-side. Features include our new "User Friendly" heavy gauge wrap around handle, large tool tray and zinc plated safety chain.



Part No. 8-14
WHEEL TYPE:
14" x 1.75" SOLID RUBBER



Part No. 8-10
WHEEL TYPE:
10" x 1.75" SOLID RUBBER



Part No. 8-24
WHEEL TYPE:
24" x 2.00" STEEL



Part No. 8-16
WHEEL TYPE:
16" x 4.00" PNEUMATIC

Solid bar threaded axles and locknuts are standard on all models.



Part No. 0081
WHEEL TYPE:
10" x 2.75" SOLID RUBBER

Part No.	Wheel Diameter & Type	Maximum Diameter Oxygen Cylinder	Maximum Diameter Acetylene Cylinder	Combined Cylinder Diameter	Height	Width (O.D.)	Weight *shippable via UPS
85-14	14" x 1.75" Solid Rubber	9 -1/2"	9"	18-1/2"	46"	25"	45 *
85-10	10" x 1.75" Solid Rubber	9 -1/2"	9"	18-1/2"	46"	25"	38 *
85-18	18" x 2.00" Steel	9 -1/2"	9"	18-1/2"	46"	27"	54
85-24	24" x 2.00" Steel	9 -1/2"	9"	18-1/2"	46"	27"	56
85-16	16" x 4.00" Pneumatic	9 -1/2"	9"	18 -1/2"	46"	29"	49 *
8-14	14" x 1.75" Solid Rubber	9 -1/2"	10-1/2"	20"	46"	27"	48 *
8-10	10" x 1.75" Solid Rubber	9 -1/2"	10-1/2"	20"	46"	26"	38 *
8-18	18" x 2.00" Steel	9 -1/2"	10-1/2"	20"	46"	27"	55
8-24	24" x 2.00" Steel	9 -1/2"	10-1/2"	20"	46"	27"	57
8-16	16" x 4.00" Pneumatic	9 -1/2"	10-1/2"	20"	46"	32"	51 *
0081	10" x 2.75" Solid Rubber	9 -1/2"	9"	18-1/2"	46"	28"	52 *



Heavy-Duty Single Cylinder Delivery Trucks

ALL MODELS ON THIS PAGE ARE SHIPPABLE VIA UPS

Designed to handle various size cylinders, these trucks will handle oxygen, acetylene, helium, propane, nitrogen, CO₂ etc. or any cyl. up to 12" in diameter. Features include a specially designed reinforced steel bottom plate that allows you to load and transport supplies or move objects safely with ease. SC MODEL TRUCKS come equipped with stair climbers to assist when handling cylinders or other objects up and down stairs or over uneven surfaces.

**These models are designed to handle up to a 12" diameter cylinder.
BB=Ball Bearing**

WHEEL TYPE:
10" x 2.75" SOLID RUBBER (BB)

WHEEL TYPE:
10" x 4.00" PNEUMATIC (BB)

WHEEL TYPE:
14" x 1.75" SOLID RUBBER (BB)

WHEEL TYPE:
10" x 4.00" PNEUMATIC (BB)

WHEEL TYPE:
10" x 2.75" SOLID RUBBER (BB)

STAIR CLIMBER MODELS

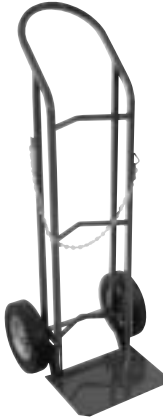

Part No. 0054
HEIGHT: 48" WIDTH: 18" (O.D.)
WEIGHT: 38 lbs.



Part No. 54PN
HEIGHT: 48" WIDTH: 22" (O.D.)
WEIGHT: 37 lbs.



Part No. 54-14
HEIGHT: 48" WIDTH: 17" (O.D.)
WEIGHT: 43 lbs.



Part No. 54PN-SC
HEIGHT: 48" WIDTH: 22" (O.D.)
WEIGHT: 39 lbs.



Part No. 54-SC
HEIGHT: 48" WIDTH: 18" (O.D.)
WEIGHT: 40 lbs.

Designed and balanced for those who transport high pressure cylinders on a daily basis, these trucks are equipped with rear assemblies that relieve the operator from a heavy load. Four popular models are available to accommodate your delivery needs. Choice of solid or pneumatic tires.

THESE MODELS HAVE A PATENTED FOLDABLE REAR ASSEMBLY THAT CAN BE QUICKLY UNLOCKED AND CLOSED FOR COMPACT STORAGE WITH LARGE 4" CASTERS, REMOVABLE FOR REPAIR OR REPLACEMENT.

Stationary Back Assembly With Large 4" Rear Casters.

WHEEL TYPE:
10" x 2.75" SOLID RUBBER (BB)

WHEEL TYPE:
10" x 4.00" PNEUMATIC (BB)

WHEEL TYPE:
10" x 2.75" SOLID RUBBER (BB)

WHEEL TYPE:
10" x 4.00" PNEUMATIC (BB)



Part No. 54-FRA
HEIGHT: 48" WIDTH: 18" (O.D.)
WEIGHT: 46 lbs.



Part No. 54PN-FRA
HEIGHT: 48" WIDTH: 22" (O.D.)
WEIGHT: 45 lbs.



Part No. 54-SA
HEIGHT: 48" WIDTH: 18" (O.D.)
WEIGHT: 42 lbs.



Part No. 54PN-SA
HEIGHT: 48" WIDTH: 22" (O.D.)
WEIGHT: 41 lbs.



Heavy-Duty Single Cylinder Delivery Trucks

ALL MODELS ON THIS PAGE HAVE A LOAD RATING OF 500 LBS.

Designed for those who need to do more than just handle cylinders on a daily basis, these trucks feature a specially constructed toeplate that allows you to load and transport supplies or move objects safely with ease. Choice of solid or pneumatic wheel models available.

WHEEL TYPE:
10" x 2.75" SOLID RUBBER (BB)



Part No. 0055
HEIGHT: 48" WIDTH: 29" (O.D.)
WEIGHT: 55 lbs.

WHEEL TYPE:
10" x 4.00" PNEUMATIC (BB)



Part No. 55PN
HEIGHT: 48" WIDTH: 33" (O.D.)
WEIGHT: 54 lbs.

These models are designed (2) cylinders
Up to 9-1/2" in diameter ea.
BB = Ball Bearing

The most popular style delivery trucks on the market, these sleek units are designed with a dual grip handle so the operator can maneuver (2) large high pressure cylinders with ease. Choice of solid or pneumatic wheel models available.

WHEEL TYPE:
10" x 2.75" SOLID RUBBER (BB)



Part No. 55-3B
HEIGHT: 48" WIDTH: 21" (O.D.)
WEIGHT: 38 lbs.

WHEEL TYPE:
10" x 4.00" PNEUMATIC (BB)



Part No. 55PN-3B
HEIGHT: 48" WIDTH: 25" (O.D.)
WEIGHT: 37 lbs.

Designed and balanced for those who transport (2) 244 to 330 cu. ft. high pressure cylinders on a daily basis, the trucks below are equipped with rear assemblies that relieve the operator from the heavy load. Four popular models are available to accommodate your delivery needs. Choice of solid or pneumatic tires.

THESE MODELS HAVE A PATENTED FOLDABLE REAR ASSEMBLY THAT CAN BE QUICKLY UNLOCKED AND CLOSED FOR COMPACT STORAGE WITH LARGE 4" CASTERS, REMOVABLE FOR REPAIR OR REPLACEMENT.

WHEEL TYPE:
10" x 2.75" SOLID RUBBER (BB)



Part No. 55-3B-FRA
HEIGHT: 48" WIDTH: 21" (O.D.)
WEIGHT: 50 lbs.

WHEEL TYPE:
10" x 4.00" PNEUMATIC (BB)



Part No. 55PN-3B-FRA
HEIGHT: 48" WIDTH: 25" (O.D.)
WEIGHT: 49 lbs.

Stationary back assembly with
large 4" rear casters.

WHEEL TYPE:
10" x 2.75" SOLID RUBBER (BB)



Part No. 55-3B-SA
HEIGHT: 48" WIDTH: 21" (O.D.)
WEIGHT: 55 lbs.

WHEEL TYPE:
10" x 4.00" PNEUMATIC (BB)



Part No. 55PN-3B-SA
HEIGHT: 46" WIDTH: 25" (O.D.)
WEIGHT: 54 lbs.



Heavy-Duty Large Oxygen / #5 or WK Acetylene Cylinder Trucks With Lifting Eye

Heavy-Duty Large Oxygen, #5 or WK Acetylene Cylinder Trucks With Lifting Eye

These models are engineered and designed for the transporting and lifting of cylinders. Features include a 5 to 1 lifting ratio, heavy-duty steel frame construction, large slotted locking tool box, our exclusive fast action cylinder placement bands and a heavy gauge reinforced toe plate. CERTIFIED ENGINEERING CALCULATIONS on these models are available upon request. **BB = Ball Bearing; RB = Tapered Roller Bearing**

WHEEL TYPE:
16" x 4.00" PNEUMATIC (BB)



Part No. 94L-16
HEIGHT: 64" WIDTH: 38" (O.D.)
WEIGHT: 79 lbs.
5:1 LIFTING SAFETY RATIO

WHEEL TYPE:
24" x 2.00" STEEL (BB)



Part No. 94L-24
HEIGHT: 64" WIDTH: 37" (O.D.)
WEIGHT: 90 lbs.
5:1 LIFTING SAFETY RATIO

WHEEL TYPE:
16" x 4.00" SOLID RUBBER (BB)



Part No. 94L-16S
HEIGHT: 64" WIDTH: 37" (O.D.)
WEIGHT: 106 lbs.
5:1 LIFTING SAFETY RATIO

WHEEL TYPE:
24" x 6.00" AUTO / RIM (RB)



Part No. 94-15L
HEIGHT: 64" WIDTH: 46" (O.D.)
WEIGHT: 148 lbs.
5:1 LIFTING SAFETY RATIO

Heavy-Duty Large Oxygen, #5 or WK Acetylene Cylinder Trucks

WHEEL TYPE:
16" x 4.00" PNEUMATIC (BB)



Part No. 94-16
HEIGHT: 47" WIDTH: 38" (O.D.)
WEIGHT: 67 lbs.

WHEEL TYPE:
24" x 2.00" STEEL (BB)



Part No. 94-24
HEIGHT: 47" WIDTH: 37" (O.D.)
WEIGHT: 78 lbs.

WHEEL TYPE:
16" x 4.00" SOLID RUBBER (BB)



Part No. 94-16S
HEIGHT: 47" WIDTH: 38" (O.D.)
WEIGHT: 90 lbs.

WHEEL TYPE:
14" x 1.75" SOLID RUBBER (BB)



Part No. 94-14
HEIGHT: 47" WIDTH: 34" (O.D.)
WEIGHT: 67 lbs.

WHEEL TYPE:
24" x 6.00" AUTO / RIM (RB)



Part No. 94-15
HEIGHT: 47" WIDTH: 46" (O.D.)
WEIGHT: 136 lbs.

Heavy-Duty Large Oxygen, #5 or WK Acetylene Cylinder Trucks With Built In Firewall & Lifting Eye

Part No. 94LFW-16
HT: 60" WIDTH: 37" (O.D.)
WEIGHT: 155 lbs.



WHEEL TYPE:
16" x 4.00" PNEU. (BB)

The ANTHONY Firewall Series is designed to restrict a flame generated from (1) acetylene or other welding fuel-gas cylinder placed adjacent to (1) oxygen cylinder on the same truck. The center baffle partition performs this function. The purpose of the center partition is to restrict a flame generated by the acetylene or other welding grade fuel-gas cylinder from heating the adjacent oxygen cylinder contents to such an extent that it causes expansion of the oxygen cylinder contents, which increases the PSI level higher than the D.O.T. prescribed safe pressure level. Should the oxygen cylinder contents be expanded beyond the D.O.T. safe level, the expanded contents could activate the safety control burst disc, which would then allow oxygen to be added to the fuel-gas cylinder generated flame, causing a more intense or expanded flame.

8:1 LIFTING
SAFETY RATIO

CERTIFIED ENGINEERING
CALCULATIONS ARE
AVAILABLE UPON REQUEST.

WHEEL TYPE:
24" x 6.00" AUTO / RIM (RB)



Part No. 94-15LFW-24
HEIGHT: 60" WIDTH: 46" (O.D.)
WEIGHT: 208 lbs.

WHEEL TYPE:
16" x 4.00" SOLID RUBBER (BB)



Part No. 94LFW-16S
HEIGHT: 60" WIDTH: 37" (O.D.)
WEIGHT: 178 lbs.



Single/Multiple D & E Size Carts

Single D & E Size Carts & Stands

Part No. 6105

HEIGHT: 41" DEPTH: 10" (O.D.)
WIDTH: 12" (O.D.) WEIGHT: 6 lbs.
CYLINDER CAPACITY: 1



Part No. 610WM

HEIGHT: 14" DEPTH: 5" (O.D.)
WIDTH: 5" (O.D.) WEIGHT: 4 lbs
CYLINDER CAPACITY: 1

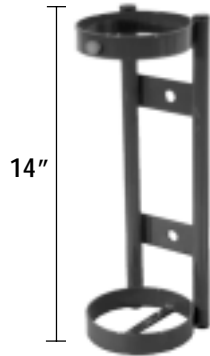

40 To 150 Cubic Ft. Cylinder Trucks

Part No. 6108-C

HEIGHT: 40" DEPTH: 12" (O.D.)
WIDTH: 13" (O.D.) WEIGHT: 14 lbs.
CYLINDER CAPACITY: 1



Part No. 6108

HEIGHT: 40" DEPTH: 12" (O.D.)
WIDTH: 13" (O.D.) WEIGHT: 12 lbs.
CYLINDER CAPACITY: 1



FITS CYLINDERS UP TO 8-1/4" IN DIA.

Multiple D & E Size Cylinder Carts & Stands



Part No.	Wheel Dia. & Type	Cylinder Capacity	Height	Width	Depth	Weight *shippable via UPS
6040	Stand	4	16"	11"	11"	10 *
6060	Stand	6	16"	11"	16"	14 *
6120	Stand	12	16"	16"	20"	21 *
6180	Stand	18	20"	16"	30"	30 *
6240	Stand	24	20"	20"	30"	38 *
6400	Stand	40	20"	25"	40"	67 *
6041	Cart - 10" x 1.75" Solid Rubber	4	42"	18"	10"	26 *
6061	Cart - 10" x 1.75" Solid Rubber	6	42"	18"	15"	30 *
6121	Cart - 10" x 1.75" Solid Rubber	12	42"	22"	15"	39 *
6124	Cart - 10" x 1.75" Solid Rubber	12	42"	22"	20"	44 *
6184	Cart - Caster Dia: 4" w/ Locks	18	42"	16"	30"	43 *
6244	Cart - Caster Dia: 4" w/ Locks	24	42"	20"	30"	50 *
6246	Cart - Caster Dia: 6" w/ Locks	24	46"	20"	30"	64 *
6406	Cart - Caster Dia: 6" w/ Locks	40	46"	25"	40"	106

Anthony Industrial Wheels and Casters

Part No.	Wheel Dia.	Width	Bore	Type	Description	Load Rating	Corresponding Model No.
0W-1	6"	1.50"	1/2"	PB	SEMI-PNEU.	30 lbs.	6105
0W-3	7"	1.50"	1/2"	PB	SOLID RUBBER	150 lbs.	0038, 038B
0W-5	8"	1.50"	1/2"	PB	SOLID RUBBER	150 lbs.	6108
W-11	10"	1.75"	5/8"	BB	SOLID RUBBER	200 lbs.	0043, 039V, 41-10, 4-10, 85-10, 8-10, 6114, 6110, 6214, 6210
W-12PN	10"	4.00"	3/4"	BB	PNEUMATIC	250 lbs.	88PN, 88PN-R, 86U-4PN, 55PN, 55PN-3B, 55PN-3B-FRA
W-13	10"	2.75"	3/4"	BB	SOLID RUBBER	300 lbs.	81, 88, 88-R, 86U-4, 55, 55-3B, 55-3B-FRA, 55-3B-SA, 54, 54-FRA
W-15	14"	1.75"	3/4"	BB	SOLID RUBBER	275 lbs.	41-14, 4-14, 85-14, 8-14, 24-14, 2-14, 54-14, 94-14,
W-17PN	16"	4.00"	3/4"	BB	PNEUMATIC	400 lbs.	41-16, 4-16, 85-16, 8-16, 24-16, 2-16, 94LFW-16, 94L-16
W-17SP	16"	4.00"	3/4"	BB	SOLID RUBBER	350 lbs.	85-16S, 8-16S, 24-16S, 2-16S, 94LFW-16S, 94L-16S
W-18	18"	2.00"	3/4"	PB	STEEL	275 lbs.	41-18, 4-18, 85-18, 8-18, 24-18, 2-18, 94LFW-18 94L-18
W-19	24"	2.00"	3/4"	PB	STEEL	275 lbs.	85-24, 8-24, 24-24, 2-24, 94LFW-24, 94L-24 94-24, 84-24
W-22	4"	1.25"	3/8"	PB	RUBBER SWIVEL / BRAKE	200 lbs.	88-R, 88PN-R, 54-SA, 54PN-SA, 6124, 6184, 6244,
W-22PS	4"	1.00"	3/8"	PB	RUBBER SWIVEL W/ POST	140 lbs.	6114, 6114-R, 6214, 55PN-3B-FRA, 55-3B-FRA, 54-FRA
W-23R	6"	2.00"	1/2"	RB	RUBBER RIGID	600 lbs.	6246, 6406
W-24R	6"	2.00"	1/2"	RB	RUBBER SWIVEL / BRAKE	600 lbs.	87U-4, 86U-4, 6246, 6406
W-26	2"	1"	1/4"	PB	SINTERED IRON	150 lbs.	87U-4, 86U-4



Cylinder Stands / Cylinder Wall Brackets / Medical Trucks

Large Single & Dual Cylinder Stands

THIS PATENTED STAND
HOLDS A 9" TO 9 1/2" CYL.



Part No. 610F
HT: 13" DEPTH: 18" (O.D.)
WIDTH: 18" (O.D.) WT: 13 lbs.

THIS PATENTED STAND
HOLDS A 7" TO 9-1/2" CYL.



Part No. 610F-E
HT: 13" DEPTH: 18" (O.D.)
WIDTH: 18" (O.D.) WT: 13 lbs.



Part No. CH-200-C
HT: 48" DEPTH: 10" (O.D.)
WIDTH: 24" (O.D.) WT: 22 lbs.
CYLINDER CAPACITY: 2

Cylinder Wall Brackets

HOLDS 7" TO 9 1/2"
DIAMETER CYLINDERS



Part No. WB-100
WIDTH: 11" DEPTH: 6"
WEIGHT: 3 lbs.



Part No. WB-100C
WIDTH: 11" DEPTH: 6"
WEIGHT: 3 lbs.



Part No. WB-200
WIDTH: 22" DEPTH: 7"
WEIGHT: 5 lbs.



Part No. WB-200C
WIDTH: 22" DEPTH: 7"
WEIGHT: 5 lbs.

HOLDS 10" TO 15 1/2"
DIAMETER CYLINDERS
(brackets not shown)

Part No. WB-100-15
WIDTH: 16" DEPTH: 12"
WEIGHT: 4 lbs.

Part No. WB-100-15C
WIDTH: 16" DEPTH: 12"
WEIGHT: 4 lbs.

Part No. WB-200-15
WIDTH: 31" DEPTH: 12"
WEIGHT: 6 lbs.

Part No. WB-200-15C
WIDTH: 31" DEPTH: 12"
WEIGHT: 6 lbs.

Large 244 - 330 Cubic Ft. Medical Cylinder Trucks

Part No. 6114 & 6214 are single & dual cylinder carts recommended for the transport & handling of large high pressure cylinders. They feature newly designed longer handles for ease of mobility, large 10" solid rubber front wheels and 4" rear casters for better maneuverability over rough or uneven surfaces. These units also come equipped with the newly designed and PATENTED rear wheel retractable assembly. (Simply extend the rear mechanism into its locked position, tilt back and use). Part No. 6114-R is equipped with a stationary rear assembly that is not retractable.



Part No. 6114
HEIGHT: 46" DEPTH: 15" (O.D.)
WIDTH: 15" (O.D.) WEIGHT: 30 lbs.
WHEEL DIA: 10" x 1.75" SOLID RUBBER (BB)
CASTER: 4" x 1" SWIVEL / POST
CYLINDER CAPACITY: 1

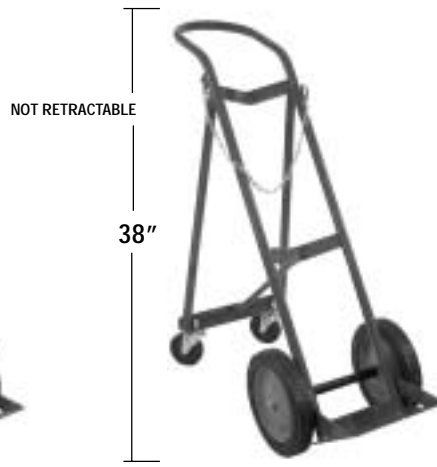

Part No. 6114-R
HEIGHT: 46" DEPTH: 28" (O.D.)
WIDTH: 15" (O.D.) WEIGHT: 30 lbs.
WHEEL DIA: 10" x 1.75" SOLID RUBBER (BB)
CASTER: 4" x 1" SWIVEL / POST
CYLINDER CAPACITY: 1

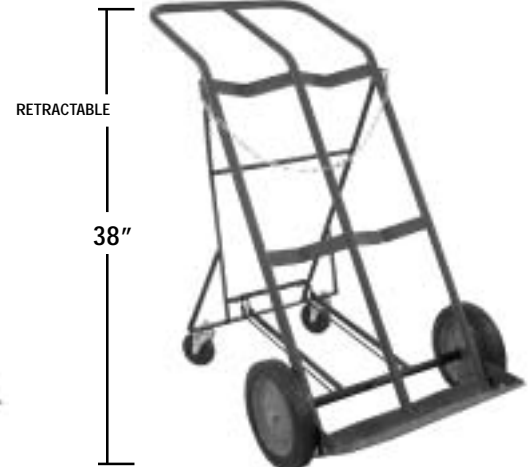

Part No. 6214
HEIGHT: 46" DEPTH: 28" (O.D.)
WIDTH: 25" (O.D.) WEIGHT: 41 lbs.
WHEEL DIA: 10" x 1.75" SOLID RUBBER (BB)
CASTER: 4" x 1" SWIVEL / POST
CYLINDER CAPACITY: 1

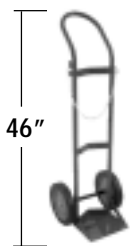

Part No. 6110
HEIGHT: 46" DEPTH: 15" (O.D.)
WIDTH: 15" (O.D.) WEIGHT: 23 lbs.
WHEEL DIA: 10" x 1.75" SOLID RUBBER (BB)
CYLINDER CAPACITY: 1



Part No. 6210
HEIGHT: 46" DEPTH: 28" (O.D.)
WIDTH: 25" (O.D.) WEIGHT: 31 lbs.
WHEEL DIA: 10" x 1.75" SOLID RUBBER (BB)
CYLINDER CAPACITY: 2



Large Cylinder Trucks

Large Liquid Cylinder Trucks

This new (patented) modern design provides for safe & easy handling of large liquid cylinders. These trucks have a fast adjusting lifting hook designed to fit a large variety of liquid cylinders on the market today. Features include a 3 point tilt design, heavy-duty reinforced lightweight tubing frame, top ring safety chain, fast adjusting nylon belly-band & large 6" heavy duty rear locking casters that can be easily removed & replaced for repair & maintenance.

HANDLES THE MOST POPULAR & TALLEST CYLINDERS ON THE MARKET TODAY. (INCLUDING - TAYLOR WARTON XL55)

LIFTING HOOK RANGE: 56-1/4" to 61-3/4" (MEASURE FROM THE GROUND TO THE TOP OF THE CYL. EYELET HOLE)



FAST ACTION SELF-SETTING "BELLY-BAND" WITH THUMB RELEASE FOR ADDED SAFETY WHEN TRANSPORTING A CYLINDER LONG DISTANCES OVER ROUGH OR UNEVEN SURFACES.



Part No. 87U-4
HEIGHT: 46" WIDTH: 28" (O.D.)
WEIGHT: 92 lbs.

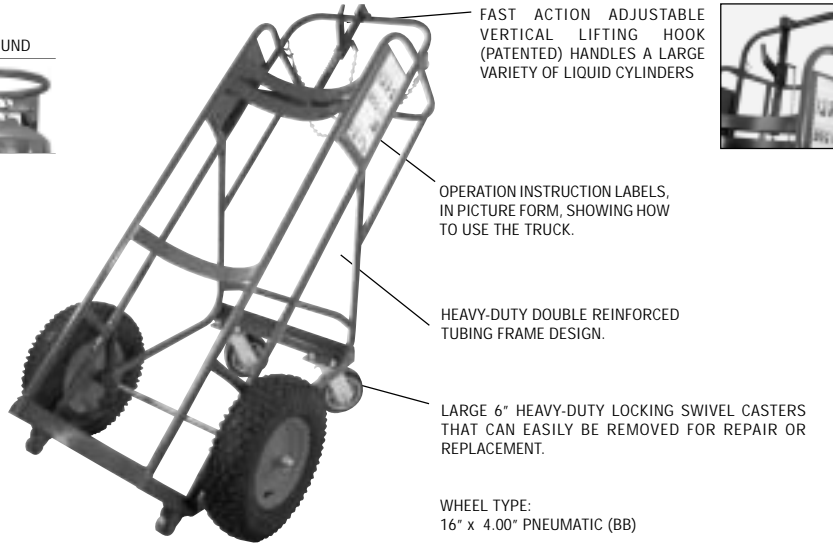

FAST ACTION ADJUSTABLE VERTICAL LIFTING HOOK (PATENTED) HANDLES A LARGE VARIETY OF LIQUID CYLINDERS



OPERATION INSTRUCTION LABELS, IN PICTURE FORM, SHOWING HOW TO USE THE TRUCK.

HEAVY-DUTY DOUBLE REINFORCED TUBING FRAME DESIGN.

LARGE 6" HEAVY-DUTY LOCKING SWIVEL CASTERS THAT CAN EASILY BE REMOVED FOR REPAIR OR REPLACEMENT.

WHEEL TYPE:
16" x 4.00" PNEUMATIC (BB)

ADDITIONAL WHEEL TYPES TO CHOOSE FROM (NOT SHOWN)

Part No. 87U-4S
HEIGHT: 46" WIDTH: 28" (O.D.)
WEIGHT: 124 lbs.
WHEEL TYPE:
16" x 4.00" SOLID RUBBER (BB)
6" x 2" SWIVEL CASTERS W/LOCKS

Part No. 86U-4PN
HEIGHT: 46" WIDTH: 28" (O.D.)
WEIGHT: 82 lbs.
WHEEL TYPE:
10" x 4.00" PNEUMATIC (BB)
6" x 2" SWIVEL CASTERS W/LOCKS

Part No. 86U-4
HEIGHT: 46" WIDTH: 26" (O.D.)
WEIGHT: 85 lbs.
WHEEL TYPE:
10" x 2.75" SOLID RUBBER (BB)
6" x 2" SWIVEL CASTERS W/LOCKS

Large Single Cylinder Trucks (Maximum Cylinder Diameter - 16")

These heavy-duty single cylinder trucks are designed to carry (1) cylinder no greater than 16" in diameter. The combination of an all welded double reinforced steel frame combined with a heavy gauge baseplate & (2) sets of safety chains makes these trucks rugged & dependable in any application.

WHEEL TYPE:
10" x 4.00" PNEUMATIC (BB)

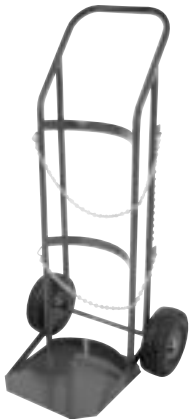

Part No. 88PN
HEIGHT: 50" WIDTH: 24" (O.D.)
WEIGHT: 38 lbs.

WHEEL TYPE:
10" x 2.75" SOLID RUBBER (BB)



Part No. 0088
HEIGHT: 50" WIDTH: 20" (O.D.)
WEIGHT: 34 lbs.

STATIONARY REAR ASSEMBLY WITH HEAVY-DUTY 4" CASTERS W/ LOCKS FOR TALLER CYLINDERS

WHEEL TYPE:
10" x 4.00" PNEUMATIC (BB)



Part No. 88PN-R
HEIGHT: 50" WIDTH: 24" (O.D.)
WEIGHT: 58 lbs.

WHEEL TYPE:
10" x 2.75" SOLID RUBBER (BB)



Part No. 88-R
HEIGHT: 50" WIDTH: 20" (O.D.)
WEIGHT: 54 lbs.